

▲ PEAKTRONICS

The Peaktronics 2nd generation DHC-500 is a high performance digital positioner intended to control 3-phase AC actuators by controlling two mechanically interlocking contactors, providing up to 450 points of resolution with actuators ranging from 15 sec to 120 sec. The DHC-500 has many automatic advanced features that will enhance any actuator while making it easy to install and set up.

The simple three button control is used to configure all parameters the unit needs for a wide variety of applications, and allows the *open* and *closed* positions to be easily set for direct or reversing acting without any rewiring. The unit can be configured for various command types (4-20mA, 1-5V, 0-5V, 0-10V, 2-10V, or a Digital command) and its position upon loss of command.

Various option modules are easily plugged into the unit, providing other features such as a position feedback signal (current or voltage), auxiliary switches, fault relay contact, or digital communications. A wide range of data is accessible through a digital communications module, providing additional control or information.

The unit is of single solid construction and is easily mounted with two screws. The DHC-500 is interchangeable with the SVC-100 series standard size controllers, and can be used to upgrade performance for those applications.

DHC-500

Digital High-Resolution 3-Phase Motor Contactor Controller

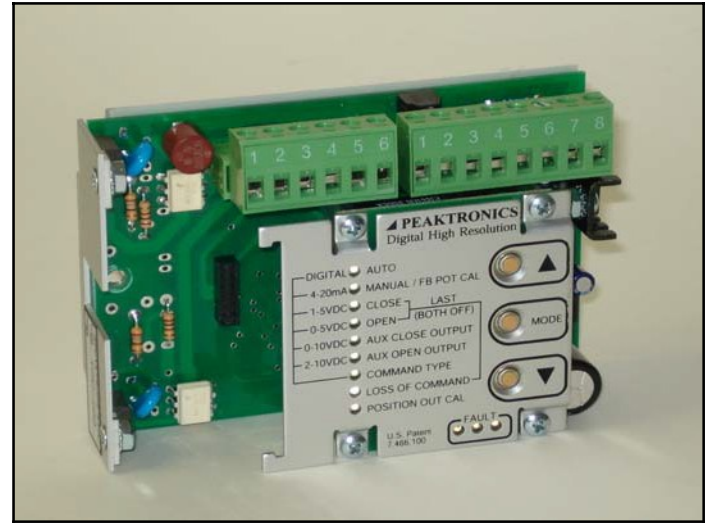

DHC-500 117VAC

FEATURES

- **Adaptive Control** feature continuously adjusts for load and actuator conditions and eliminates calibration procedures and auto-cal operations.
- **Polarity Detection** feature allows direct or reverse acting operation without re-wiring.
- **Stall Detection** feature turns off contactors when a stall condition is detected.
- **Automatic Duty Cycle Control** feature prevents shutdown of a process due to a thermal overload of the actuator motor, and allows actuators rated for 25% duty or more to be safely used.
- Operating temperature range 0 to 60°C, for temperatures outside this contact Peaktronics.

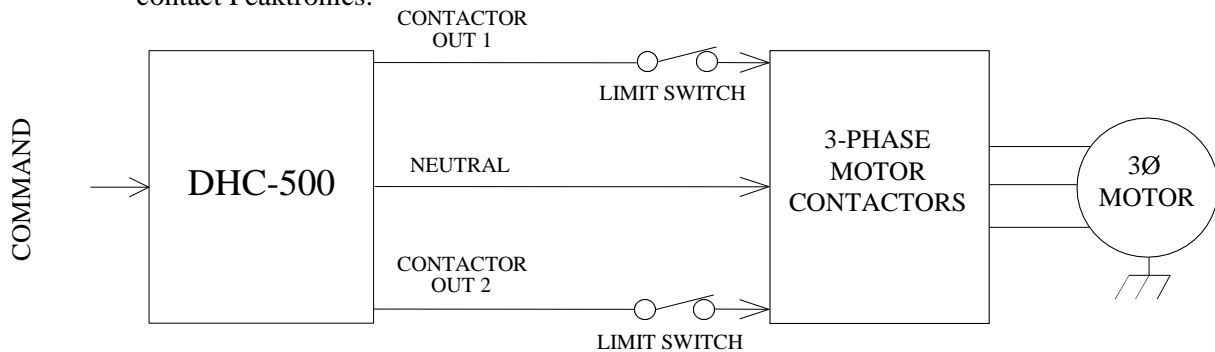

TYPICAL 3-PHASE MOTOR DRIVEN ACTUATOR

BLOCK DIAGRAM

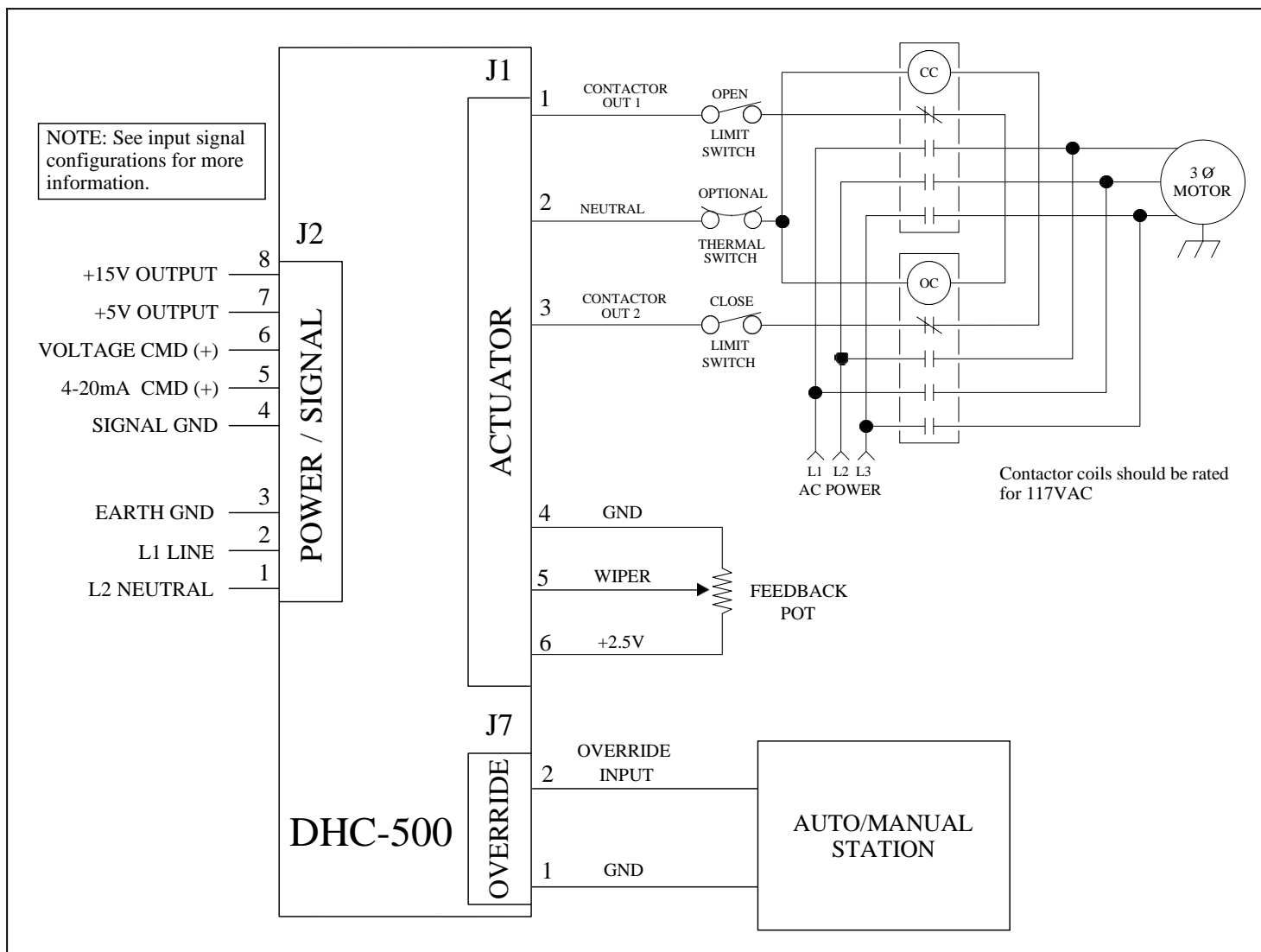

DESCRIPTION

The DHC-500 requires a single phase 117VAC $\pm 10\%$ power supply. This can be a separate power supply or a single phase supply derived from two legs of the three phase motor power. The unit is easily mounted with two screws and is equipped with removable screw terminals that provide for easy field wiring. The unit's size and mounting are compatible with Peaktronics standard positioners and can be mounted with any Peaktronics mounting kit for standard positioners.

The simple three button control (MODE, ▲, and ▼) allows the user to perform a complete set-up from the unit itself without the need for any instrumentation. The adaptive control feature of the DHC-500 eliminates the need for any calibration steps. In the simplest application, only the *closed* and *open* positions need to be set and the unit automatically and continuously sets all other parameters when placed in the AUTO mode.

INSTALLATION

SHOCK HAZARD! These units are intended to be mounted in an appropriate enclosure connected to earth ground through wiring or piping. High voltages are present on the outside of the unit when power is applied. The power source should be disconnected prior to any wiring of these units to avoid an electrical shock.

OUTDOOR CONSIDERATION! A heater and thermostat should be used where low temperatures and/or condensation may occur. Installing a clay based desiccant packet at the time of final access prior to sealing the cover is highly recommended. This will reduce the dew and frost points by reducing the relative humidity inside the actuator.

POWER / SIGNAL (J2)

Power is connected to pins 1, 2, and 3 as shown in the block diagram. The fuse installed on the unit is rated for maximum output current that can be safely delivered by contactor outputs 1 & 2. Replacement fuses must not exceed the maximum rating to prevent damage to the unit.

An appropriate command signal, either 0-5V, 0-10V, 1-5V, 2-10V, or 4-20mA, should be connected to pin 5 or 6 (as shown in the Block Diagram) while using pin 4 as the return *signal ground*. The DHC-500 must be configured for the type of command signal that is to be used (see COMMAND TYPE).

Pin 7 of J2 provides an auxiliary +5V output which can be used to connect a command potentiometer. By connecting one end of a potentiometer to pin 7, the other end to pin 4, and the wiper to pin 6, a local control knob can be implemented. Pin 8 provides an auxiliary +15VDC output which can be used to power an input or output 4-20mA transmitter.

ACTUATOR (J1)

The contactors and feedback potentiometer are connected to J1 as shown in the Block Diagram. The neutral or common wire of both contactor coils must be connected to pin 2, while the open coil is connected to pin 1 and the other close coil to pin 3.

The feedback potentiometer wiper must be connected to pin 5, while one end is connected to pin 4 and the other end to pin 6. The **Polarity Detection** feature of the DHC-500 automatically determines which contactor to control based on where the *open* and *closed* positions are set; this feature also eliminates the need to rewire the unit for direct or reverse acting applications.

When the ▲ and ▼ buttons are used to control the actuator, the ▲ button will turn on the contactor connected to pin 1, while the ▼ button will turn on the contactor connected to pin 3. See MANUAL/FB POT CAL for more details.

OVERRIDE (J7)

J7 provides a simple 2-wire connection that can override the DHC-500 to perform a variety of external control functions. Using an appropriate interface module, commonly used auto/manual station switches are easily implemented with low voltage/low current switches. See Special Applications for more details. The factory installed jumper between pins 1 and 2 enables normal operation of the DHC-500 and must be installed if the external override functions are not used.

MODE

The MODE button is used to select the desired function of operation. When the MODE button is pressed, the unit will switch to the next function and the appropriate LED indicator will turn on to let the user know which function is selected. Except for the MANUAL/FB POT CAL mode, the associated mode indicator will be steady on; for some of the modes other indicators will flash to indicate specific settings associated with the mode. Each of the modes are described in more detail in the following sections.

If a 0-5V or 0-10V command signal is used, the LOSS OF COMMAND function cannot be used. The MODE button will skip over the LOSS OF COMMAND mode when the unit is configured for a 0-5V or 0-10V command signal (see COMMAND TYPE). When the OVERRIDE mode is enabled (see OVERRIDE MODE), the MODE button is disabled and the Manual/FB Pot Cal indicator will turn on steady.

ADJUST UP (▲) and ADJUST DOWN (▼)

The adjust up (▲) and adjust down (▼) buttons are used to adjust the setting of any given function. When a function is selected by the MODE button, the adjust buttons will affect that function only. Note, that the AUTO mode does not have any adjustable settings, and therefore, the adjust up (▲) and adjust down (▼) buttons have no effect. Also, the adjust buttons are disabled in the OVERRIDE mode.

OVERRIDE MODE

The OVERRIDE mode is not selected by the MODE button and can be enabled at anytime by connecting a resistance greater than 250 ohms to the Override Input (J7 pin 1 and pin 2). While the OVERRIDE mode is enabled, the MODE button and adjust buttons are disabled, and the Manual/FB Pot Cal indicator will turn on steady to indicate that the unit is being controlled by the Override Input. Shorting J7 pin 1 to pin 2 returns the unit to normal operation and the previously selected mode.

Controlling the DHC-500 from the Override Input is accomplished by connecting a specific resistance to select a specific operation. The table below defines the operations and their associated resistance. See Special Applications for details on using the Override Input for an Auto/Manual Station.

OPEN

The OPEN function works the same way as the CLOSE function with the exception that the adjust buttons are used to set the desired *open* position. As with the CLOSE function, upon selecting the OPEN function, the actuator will move to the previously set *open* position. Once the desired position is set, the DHC-500 will automatically correspond a command signal input of 10V, 5V, 20mA, or 100% to the *open* position.

AUX CLOSE OUTPUT

The AUX CLOSE OUTPUT function is used to set an optional output setting that is associated with the *closed* position - an appropriate relay option module is required to use this output. The adjust buttons are used to set the actuator to a desired position. Whenever the actuator position falls between the defined *closed* position and the Aux Close position, the Aux Close Output indicator will flash. Additionally, the DHC-500 will turn on a relay output on the optional relay module - the output can be used to drive an alarm or merely act as an auxiliary limit switch.

Upon selecting the AUX CLOSE OUTPUT function, the DHC-500 will begin moving the actuator to the previously set position. It is not necessary to make an adjustment if the unit has been previously set to the desired position.

AUX OPEN OUTPUT

The AUX OPEN OUTPUT function is used to set an optional output setting that is associated with the *open* position - an appropriate relay option module is required to use this output. The adjust buttons are used to set the actuator to a desired position. Whenever the actuator position falls between the defined *open* position and the Aux Open position, the Aux Open Output indicator will flash. Additionally, the DHC-500 will turn on a relay output on the optional relay module - the output can be used to drive an alarm or merely act as an auxiliary limit switch.

Upon selecting the AUX OPEN OUTPUT function, the DHC-500 will begin moving the actuator to the previously set position. It is not necessary to make an adjustment if the unit has been previously set to the desired position.

COMMAND TYPE

The COMMAND TYPE function is used to configure the command signal input for either 4-20mA, 1-5V, 0-5V, 0-10V, 2-10V, or Digital to match the type of command signal being used. Upon selecting the COMMAND TYPE function, the Command Type indicator will turn on steady, while the indicator for the selected type will flash. Use the adjust buttons (▲ or ▼) to select the desired input type. The selection will be saved when the MODE button is pressed, which will also advance the unit to the LOSS OF COMMAND function.

LOSS OF COMMAND

When using 1-5V, 2-10V, 4-20mA, or a Digital input type for the command signal, the DHC-500 will detect when the command signal is lost or out of range. A loss of command condition is detected whenever the input is disconnected, the input becomes less than 0.75V (for 1-5V input), 1.5V (for 2-10V input) or 3mA, or the input is connected backwards. An out of range condition is detected whenever the input becomes greater than 5.25V (for 1-5V input), 10.5V (for 2-10V input), or 21mA. If the DHC-500 detects a loss of the command, a fault will be indicated (see FAULT INDICATORS), and the actuator will be moved to one of three preset positions: the *open* position, the *closed* position, or the position last attained prior to losing the command signal. The LOSS OF COMMAND function is used to set the desired default position.

When the LOSS OF COMMAND function is selected, the adjust buttons are used to set the default position. The DHC-500 indicates the selected default setting by flashing the Open function indicator for the *open* default position, or it will flash the Close function indicator for the *closed* default position. When neither indicator is on, then the "last position" default is selected.

When a 0-5V or 0-10V command signal is used, a loss of command signal cannot be reliably detected. Therefore, if the unit is configured for a 0-5V or 0-10V command signal (see COMMAND TYPE), the MODE button will not select the LOSS OF COMMAND function. However, the DHC-500 can detect when a 0-5V or 0-10V command signal is out of range (i.e., greater than 5.25V or greater than 10.5V) or connected backwards. When an out of range condition is detected for a 0-5V or 0-10V input, the motor is turned off (leaving the actuator in its "last position") and a fault will be indicated (see FAULT INDICATORS).

POSITION OUT CAL

The POSITION OUT CAL function is used to calibrate an optional feedback transmitter output. An appropriate transmitter option module is required to use this feature. When the POSITION OUT CAL function is first selected (by pressing the MODE button while in the LOSS OF COMMAND function), the CLOSE indicator will flash, and the voltage or current associated with the *closed* position will appear at the option module output. If desired, the output can be adjusted (using the adjust buttons) to any value from 0 to 10V (for a voltage output) or 4 to 20mA (for a current output). The new setting is saved when the MODE button is pressed.

Pressing the MODE button again will leave the unit in the POSITION OUT CAL function except that the OPEN indicator will flash, and the output voltage or current associated with the *open* position will appear at the option module output. Like the *closed* setting, the output can be adjusted to any voltage (from 0 to 10V) or current (from 4 to 20mA), and the new setting is then associated with the *open* position.

FAULT INDICATORS

The DHC-500 detects various fault conditions that prohibit the unit from controlling the actuator. A combination of the three Fault indicators (red, yellow, and green) will turn on or flash to indicate a specific detected fault. If an appropriate relay option module is installed, the Fault relay output on the option module will turn off (indicating a fault) when any of the Fault indicators turn on or flash. A communications option module can also read the specific conditions causing a fault. Note that a fault condition DOES NOT disable the contactor outputs when manually controlling the actuator with the adjust buttons; while useful for troubleshooting, care should be exercised when operating the contactors under a fault condition. The OVERRIDE mode can also operate the motor when a fault condition exists - see OVERRIDE MODE for details. The Fault conditions are summarized below.

RED	YEL	GRN	FAULT
flash	flash	OFF	Contactor 1 No Motion (Stall)
flash	OFF	flash	Contactor 2 No Motion (Stall)
flash	flash	flash	Double No Motion (Stall)
OFF	OFF	flash	Feedback Alarm
OFF	flash	OFF	Loss of Command
OFF	ON	OFF	Command Out of Range
OFF	flash	flash	Feedback Alarm and Loss of Command
OFF	ON	flash	Feedback Alarm and Command Out of Range

Note that the indicators may not indicate all the fault conditions that may exist. This means that when the indicated fault is corrected, the unit may display another fault that has not been corrected. The following provides a description of each fault.

Contactor 1 No Motion (Stall) - A fault condition is detected when no actuator motion is detected while the contactor 1 output is turned on. The fault condition will disable the contactor 1 output only, and the fault is cleared when the DHC-500 detects a motion greater than 1.5° in either direction. The fault can be cleared if 1) the command signal commands a contactor 2 operation, 2) manual operation with the adjust buttons results in a motion greater than 1.5°, or 3) a mechanical manual override forces the 1.5° motion, provided the mechanical motion is monitored by the feedback pot.

Contactor 2 No Motion (Stall) - A fault is detected when no actuator motion is detected while the contactor output is turned on. The fault can be cleared in the same manner as a contactor 1 Stall (see above).

Double No Motion (Stall) - If the DHC-500 detects no actuator motion in either direction, both contactor outputs will be disabled. The command signal cannot clear this condition; only manual operation or a mechanical override can clear the fault. Alternatively, the DHC-500 can be powered off and then on to temporarily clear the fault; however, this practice should be avoided without permanently correcting the cause of such a fault.

Feedback Alarm - A fault condition is detected whenever the feedback signal is out of range (that is, less than 5% of the potentiometer value or more than 95% of the potentiometer value), or when any of the potentiometer connections are broken. Normal operation resumes when the potentiometer is reconnected or back in range.

Loss of Command - If the command signal is disconnected, the fault indication will remain on until the signal is reconnected. See LOSS OF COMMAND for details.

Command Out of Range - If the command signal goes out of range, the fault indication will remain on until the signal is back in range. See LOSS OF COMMAND for details.

DUTY CYCLE CONTROL FEATURE

The **Duty Cycle Control** feature of the DHC-500 allows actuators rated at 25% duty or more to be safely used in automated valve applications. The DHC-500 accurately monitors the relative heating of the motor and automatically duty cycles the unit at a safe level when a process becomes unstable, or if a control loop is not properly set. While the thermal switch in the motor protects the motor from overheating, thermal switches can shutdown the actuator for ten minutes or more. Further, typical thermal switches do not activate until temperatures inside the actuator become too high for other components in the actuator.

The **Duty Cycle Control** feature allows continuous operation of the motor until it detects an excess heat build up in the motor (usually well below the limit of the thermal switch). At that time, duty cycle operation is automatically enabled and continues until the motor cools enough to resume continuous operation. The duty cycle period is approximately 2 seconds with an on time that automatically varies depending on the heating of the motor. While this operation slows down the actuator's operation, it does not impact the resolution performance of the DHC-500, and it prevents disruption of a process due to a thermal switch shutdown.

STALL DETECTION FEATURE

The **Stall Detection** feature of the DHC-500 (see **FAULT INDICATORS**) does not measure torque, but rather it measures motion. The **Stall Detection** feature is useful for detecting when any of the contactor wires become disconnected. When the actuator reaches its limit of travel, the DHC-500 may also detect this as a stall. To avoid this condition, the closed and open positions, as set by the **CLOSE** and **OPEN** functions, should be set to a position away from these limits.

OPTION MODULES

Various option modules can be plugged into the DHC-500 option module connector, J3. Option modules provide additional features such as position feedback signals, auxiliary switch outputs, or digital communications.

Contact the factory for the latest available modules. Refer to the diagram below for instructions on installing an option module.

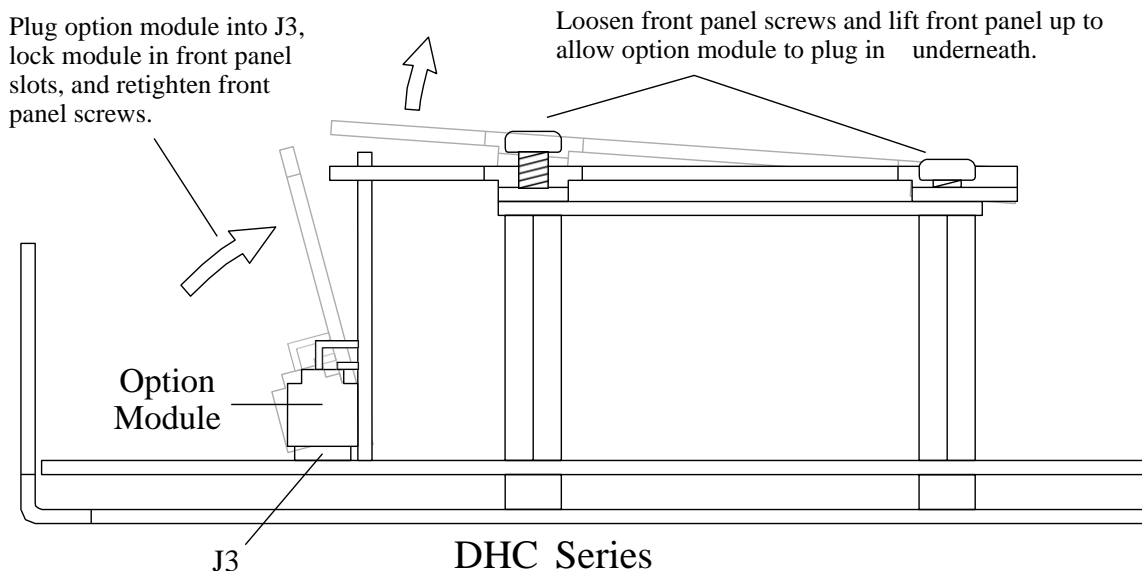

DHC Series
Installing an Option Module

SPECIFICATIONS

POWER REQUIREMENTS

DHC-500: 117VAC \pm 10%, 50/60 Hz
12 VA typical (not including output load)
FuseType: 6.3A TR5 Time Delay (replaceable)

COMMAND SIGNAL INPUT

Input Impedance
20K ohms (VOLTAGE CMD (+) Input)
251 ohms \pm 1% (4-20 mA CMD (+) Input)
Loss of Command threshold
< 0.75V (1-5 VDC input)
< 1.5V (2-10 VDC input)
< 3mA (4-20mA input)
Command Out of Range threshold
> 5.25V (0-5 VDC, 1-5 VDC input)
> 10.5V (0-10 VDC, 2-10 VDC input)
> 21mA (4-20mA input)

FEEDBACK SIGNAL INPUT

Input Voltage: 0 to 2.5 VDC
External Feedback Potentiometer: 1K ohm

POWER SUPPLY OUTPUTS

+15V OUT (J2-8): 100mA maximum (not including option module)
+5V OUT (J2-7): 20mA maximum
NOTE: *Do not* connect these outputs to other power supplies.

CONTACTOR OUTPUTS

Off-state Leakage Current: <5mA
Maximum Load Current @ 60°C: 5A

ENVIRONMENTAL

Operating Temperature Range: 0 °C to 60 °C
Storage Temperature Range: -40 °C to 85 °C
Relative Humidity Range: 0 to 90 % (noncondensing)

WIRING DIAGRAMS

Input Signal Configurations

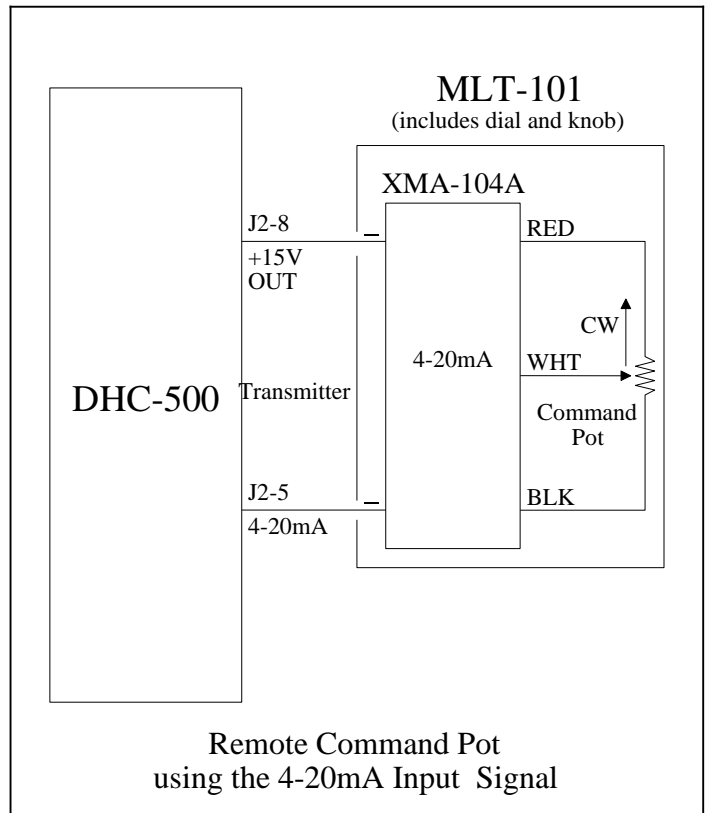
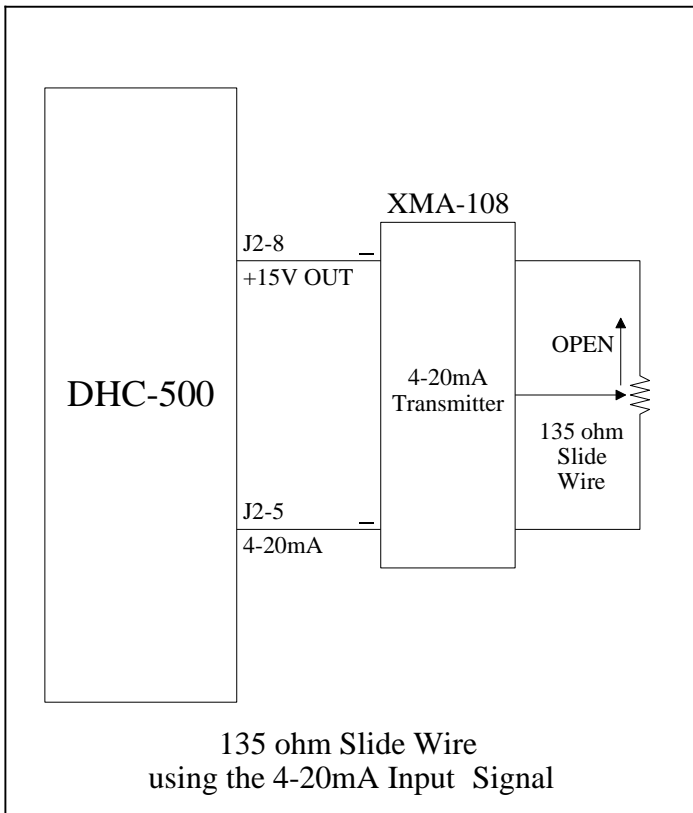
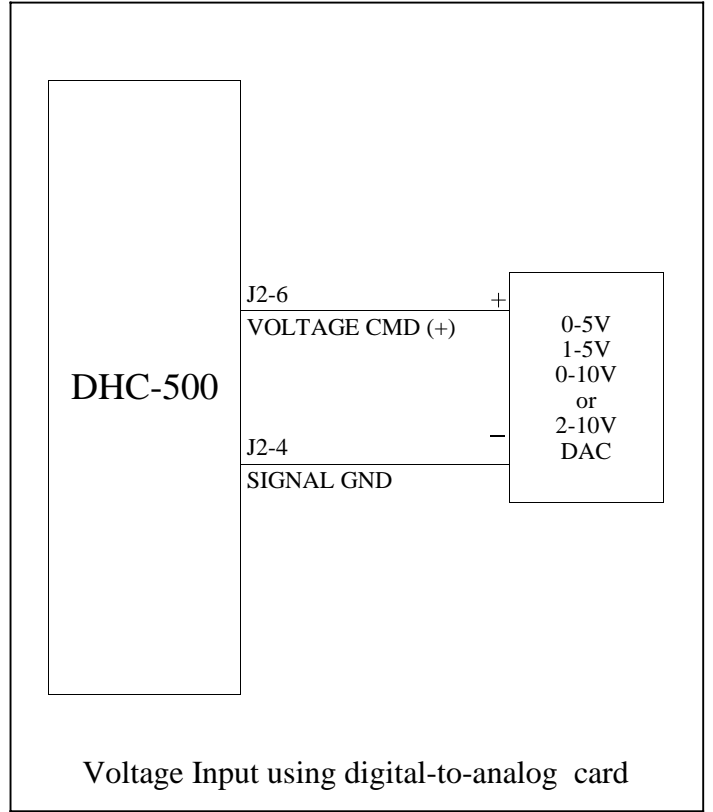
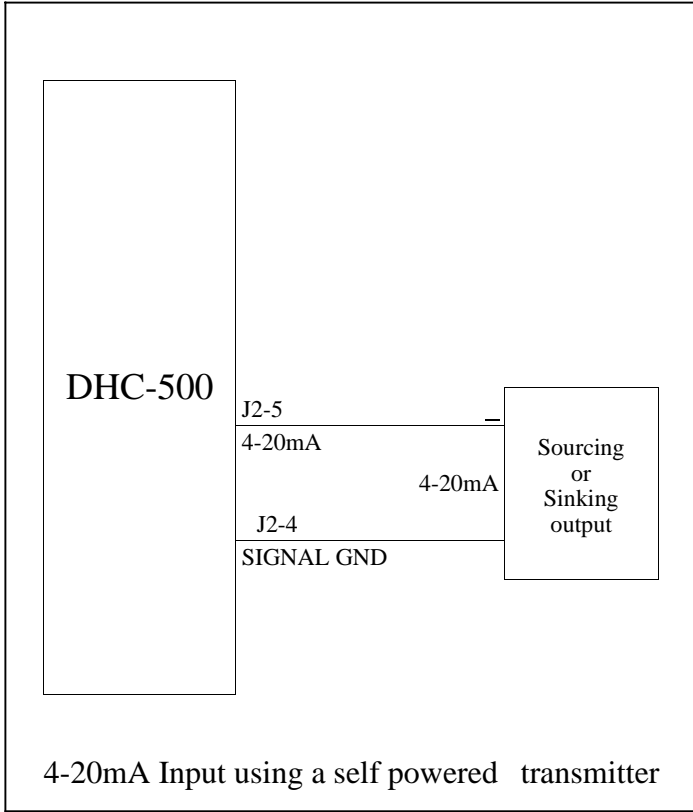

WIRING DIAGRAMS

Special Applications

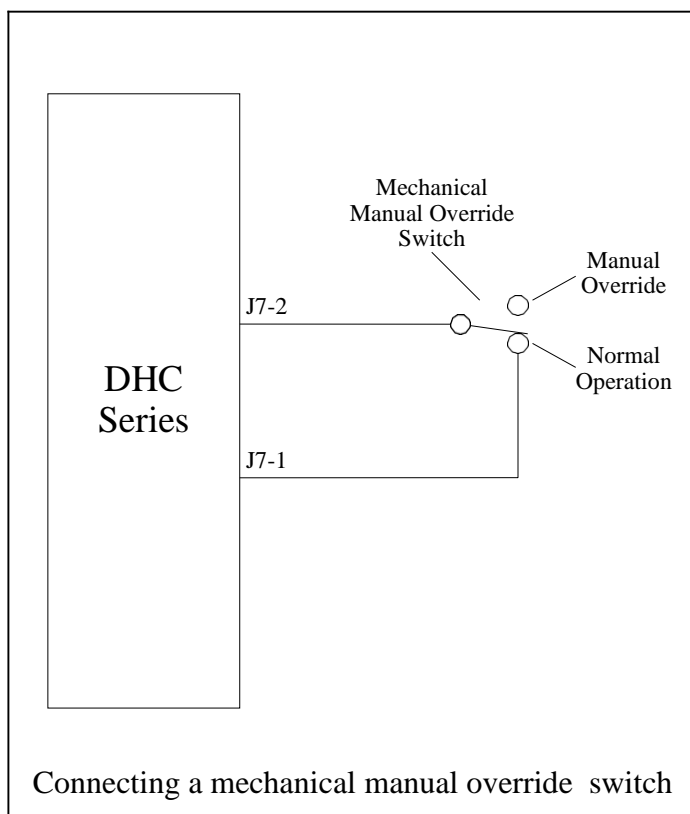
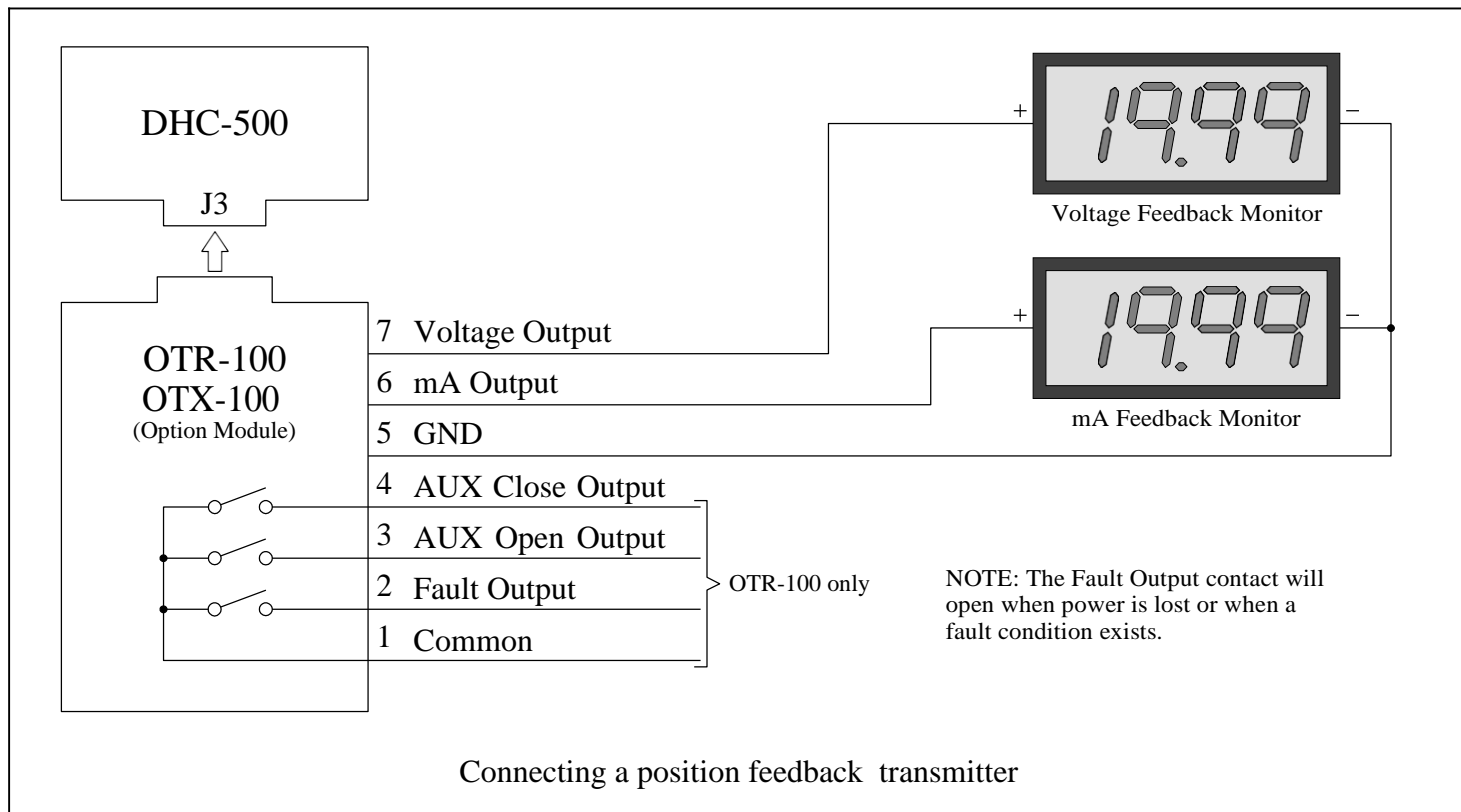

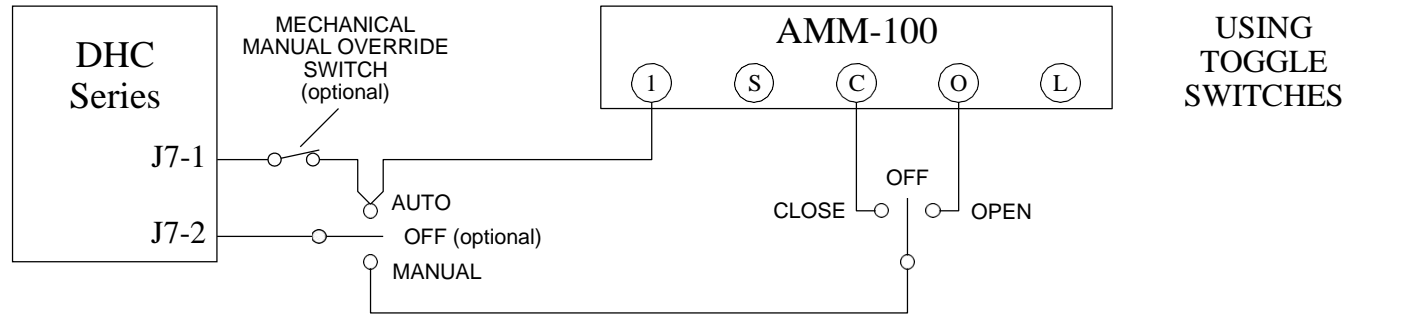
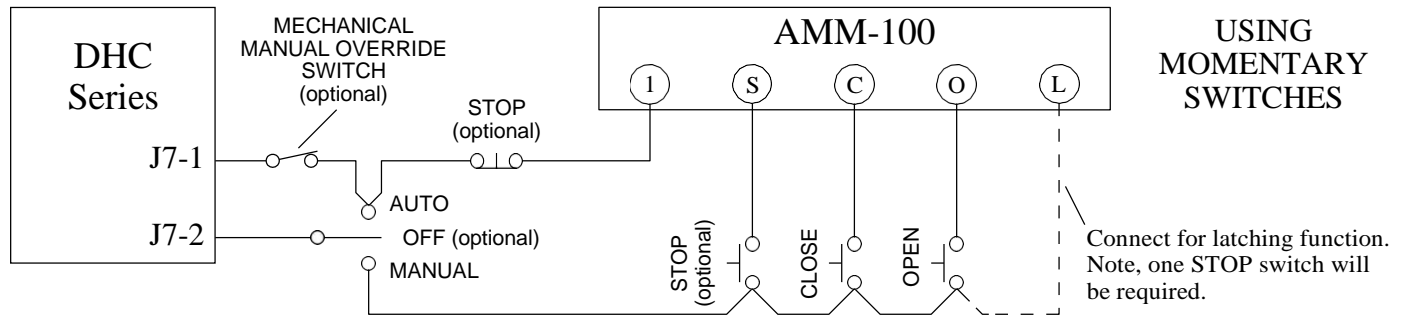

Connecting an auto/manual station