

▲ PEAKTRONICS

The Peaktronics Pneumatic Power Loop Modules are used for proportional positioning of pneumatic actuators and are intended to replace conventional I/P positioners while achieving far greater accuracy. The PPL-100R Remote Module resides in the actuator's switch enclosure and receives power and a command signal over the 2-wire Power Loop. The Remote Module also sends a position feedback signal back over the same two wires. In many applications, the Power Loop can utilize the same wiring already in place for an I/P positioner.

The PPL-100C/PPL-101C Command Module resides in an electrical control panel where AC power, command signals, and panel displays are commonly accessible. The Command Module provides an interface to commonly available signals and converts them to the Power Loop signal to be used by the Remote Module. The PPL-100C operates on 117VAC $\pm 10\%$, 50/60 Hz while the PPL-101C operates on 234VAC $\pm 10\%$, 50/60 Hz.

A command signal of 0-10V, 1-5V, or 4-20mA is connected to the Command Module which sends the signal to the Remote Module over the Power Loop. The Remote Module compares the command signal to a feedback signal from a potentiometer. The *open* or *close* solenoids connected to the Remote Module activate to move the actuator until the feedback signal matches the command signal, at which time the outputs are turned off and the actuator stops. The Remote Module sends the feedback potentiometer signal to the Command Module over the Power Loop, where the Command Module provides two output signals for position feedback, either 0-10V or 4-20mA.

An optional *fail* solenoid can be connected to the Remote Module that can be used for a variety of failsafe operations. The *fail* solenoid would be used to purge air from the actuator to achieve a desired failsafe position if power to the Remote Module was lost.

With a 1-5V or 4-20mA command signal, the Command Module can detect a loss of command and prompt the Remote Module to activate one of three responses: fail in place (*last*), the *open* output on, or the *close* output on - the loss of command selection is field configurable with jumper plugs. Other Remote Module adjustments consist of Deadband and non-interactive Zero and Span trimmers, which allows for easy field calibration.

The Command Module is mounted on Snaptrack® for easy mounting in electrical panels and has removable

PPL-100C PPL-101C PPL-100R

Pneumatic Power Loop Modules

PPL-100C
PPL-101C

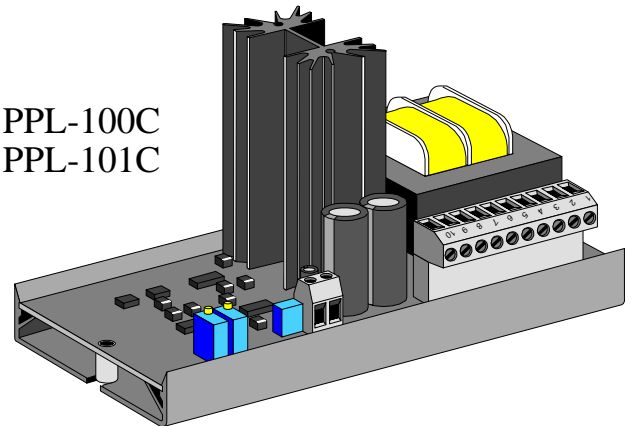

PPL-100R

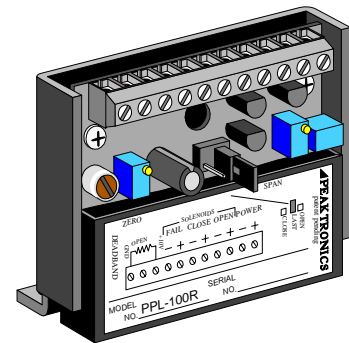

screw terminals for easy field wiring and servicing. The module also provides a +10V power output for a command potentiometer and a +24V power output for a 4-20mA input transmitter.

The Remote Module is encapsulated with a wrap around heatsink/mounting bracket and dissipates approximately 4.8W which can eliminate the need of commonly used heaters. LED indicators on the Remote Module indicate status: *open* solenoid "ON" (red), *close* solenoid "ON" (green), and Power Loop connected (yellow).

Snaptrack® is a registered trademark of Augat/RDI.

OUTLINE

PPL-100C 117VAC
 PPL-101C 234VAC

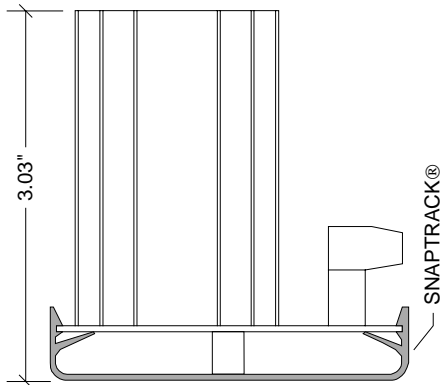
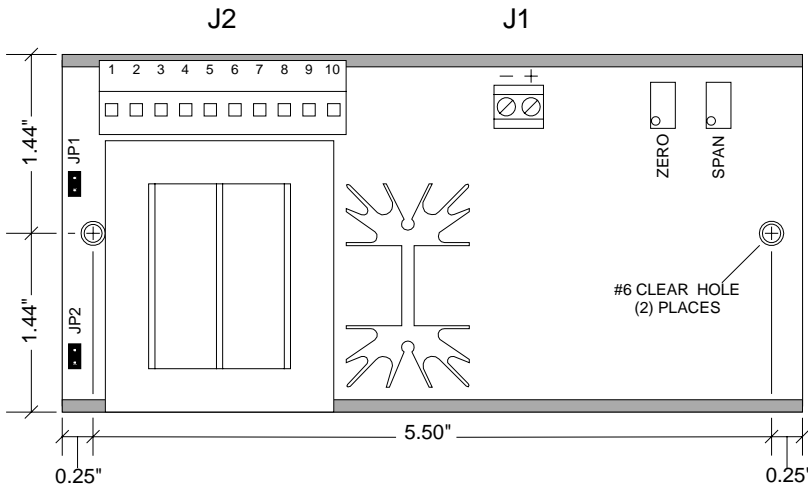

INPUT SIGNAL		
INPUT SIGNAL RANGE	JUMPER PLUG	
	JP1	JP2
0-10V	INSTALL	REMOVE
1-5V	REMOVE	INSTALL
4-20mA	INSTALL	INSTALL

ELECTRICAL CONNECTIONS

J2

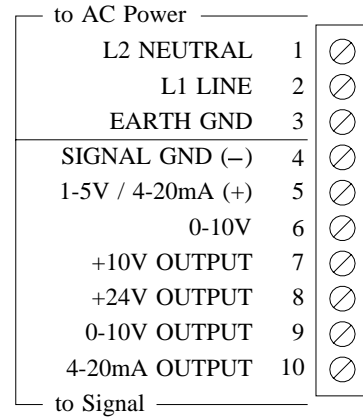

J1

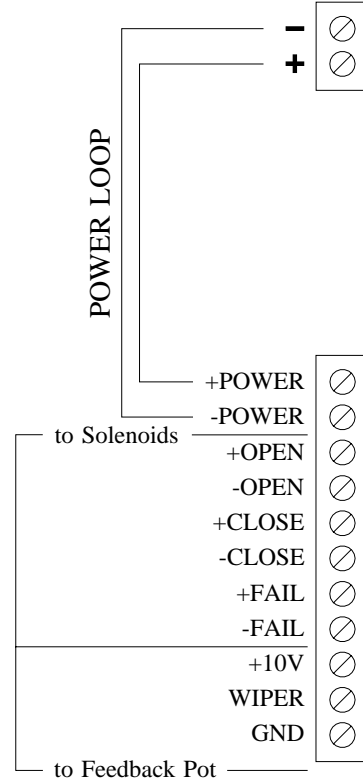

PPL-100R

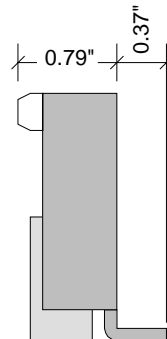
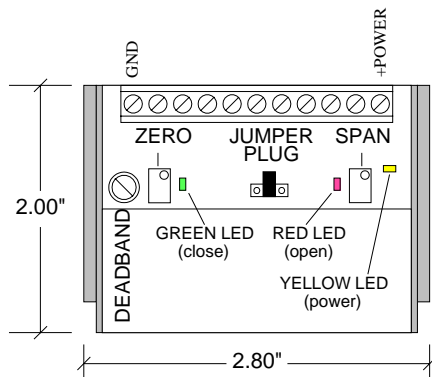
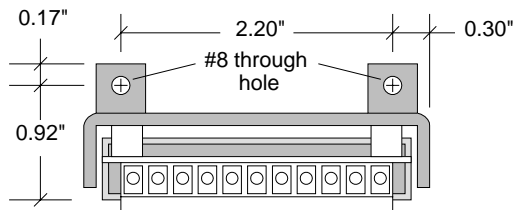

LOSS OF COMMAND	
OUTPUT STATE	JUMPER PLUG
BOTH OFF	
OPEN ON	
CLOSE ON	

BLOCK DIAGRAM

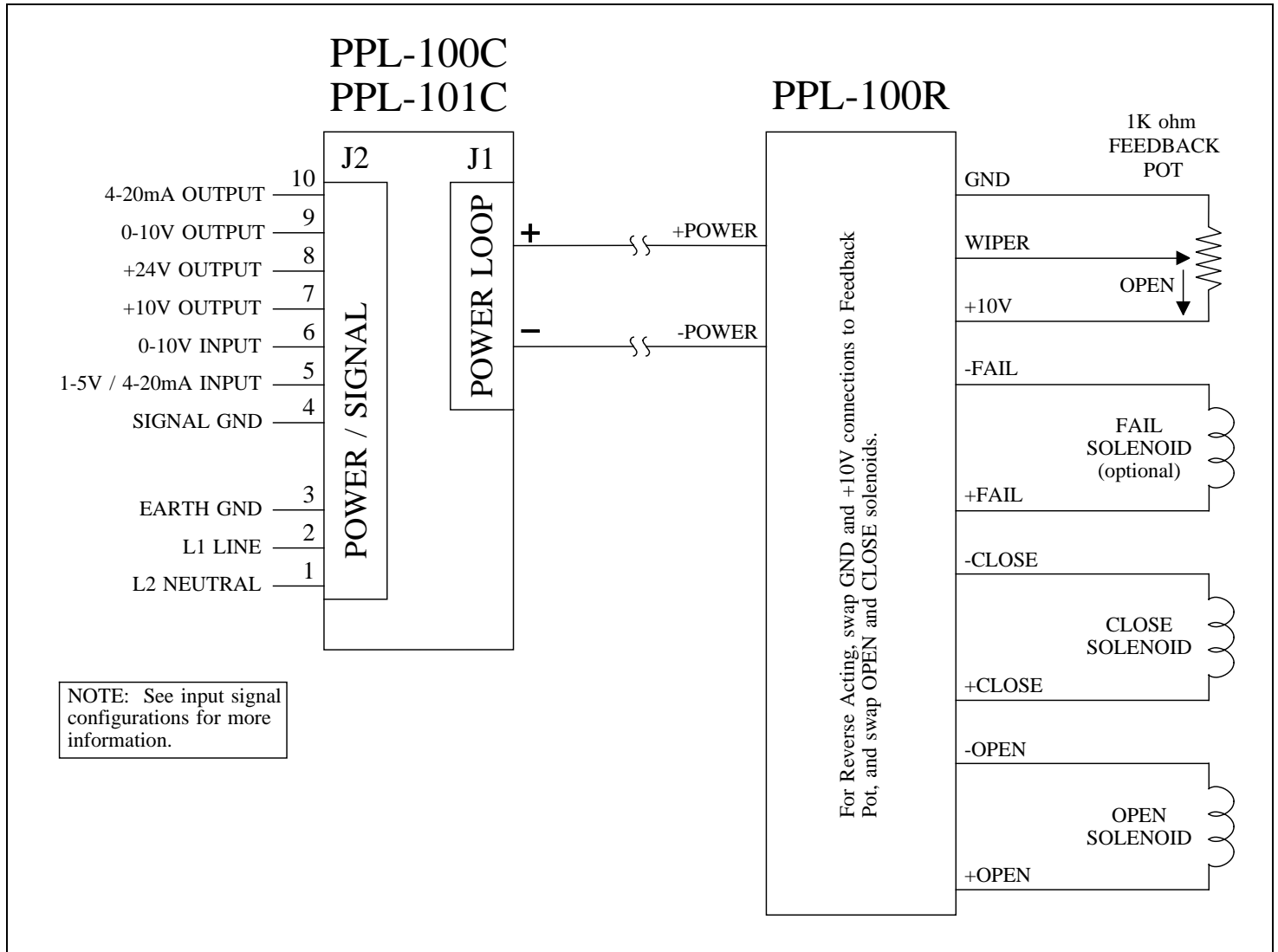

DESCRIPTION

The PPL-100C/PPL-101C Command Module and the PPL-100R Remote Module function as a pair to provide proportional control of pneumatic actuators and return position feedback. The Command Module is intended to be mounted in an electrical panel where AC power and signal connections are normally made, while the Remote Module is intended to be mounted in a pneumatic actuator's switch enclosure. Over the two-wire Power Loop connection, the Command Module provides power to the Remote Module, sends the command signal, and receives the position feedback signal. The module pair replaces traditional I/P Positioners in new or existing installations using the same two-wire connection.

The PPL-100C/PPL-101C Command Modules can be configured to accommodate various applications (see Outline information). The PPL-100C operates on 117VAC, while the PPL-101C operates on 234VAC. The Command Module also provides a +10V power output for a command potentiometer and a +24V power output for a 4-20mA input transmitter.

The PPL-100R Remote Module is encapsulated with a wrap around heatsink/mounting bracket that dissipates approximately 4.8W. The heat provided by the PPL-100R can eliminate the need for commonly used heaters. All power and signals to the Remote Module are provided by the Command Module over the two-wire Power Loop.

COMMAND MODULE CONNECTIONS (J2)

AC Power (117VAC for PPL-100C, 234VAC for PPL-101C) is connected to pins 1, 2, and 3 as shown in the block diagram.

An appropriate command signal, either 0-10V, 1-5V, or 4-20mA, should be connected to pin 5 or 6 (as shown in the Block Diagram) while using pin 4 as the return *signal ground*. The PPL-100C/PPL-101C must be configured for the type of command signal that is to be used (see Outline for details).

Pin 7 of J2 provides an auxiliary +10V output which can be used to connect a command potentiometer. By connecting one end of a potentiometer to pin 7, the other end to pin 4, and the wiper to pin 6, a local control knob can be implemented. Pin 8 provides an auxiliary +24VDC output which can be used to power an input 4-20mA transmitter.

POWER LOOP

The Peaktronics Power Loop connects the PPL-100C Command Module to the PPL-100R Remote Module using only two wires. As with a 4-20mA signal, the Power Loop is short circuit protected. Connect the "+" terminal of J1 on the Command Module to the +POWER terminal on the Remote Module, and connect the "-" terminal to -POWER as shown in the Block Diagram.

The Power Loop can be connected using twisted pair, zip cord, or shielded cable. When using shielded cable, connect the shield to EARTH GND (J2-3) on the Command Module while leaving the shield unterminated at the Remote Module end.

Since the Power Loop operates at a higher current than conventional 4-20mA signals, proper wire size should be considered when separating the Command and Remote modules over long distances. The table below shows the maximum recommended distances for various wire sizes. To avoid interference with the signals, the cable should not be coiled on a spool anywhere in the Power Loop connection.

WIRE SIZE	MAXIMUM CABLE LENGTH
24 AWG	400 ft
22 AWG	800 ft
20 AWG	1000 ft
18 AWG	1600 ft

REMOTE MODULE CONNECTIONS

The PPL-100R Remote Module provides the connections to the pneumatic actuator. The solenoid that moves the actuator toward *open* should be connected to the +OPEN and -OPEN terminals, while the solenoid that moves the actuator toward *closed* connects to the +CLOSE and -CLOSE terminals.

The PPL-100R can be used in a variety of failsafe operations. The +FAIL and -FAIL outputs are powered with 24VDC whenever power from the Power Loop is present. When power is lost, an optional fail solenoid can be used to purge air from the actuator to force the desired failsafe position - application assistance is available from Peaktronics.

The PPL-100R can power solenoids up to 3W. Since the fail solenoid is always powered, the power available for the open or close solenoid is reduced. For example, if a 1W fail solenoid is used, the open or close solenoid must not exceed 2W.

The feedback potentiometer wiper must be connected to the WIPER terminal. One end of the potentiometer is connected to the GND terminal, and the other is connected to the +10V terminal. The potentiometer should be connected so that when the actuator moves towards the *open* position, the potentiometer's resistance between GND and WIPER will increase. This can also be measured as a voltage - the voltage between GND and WIPER should increase when the actuator moves towards the *open* position. If the potentiometer is wired incorrectly, the typical response of the unit will be to run the actuator to the full open or closed position (the appropriate output indicator will remain on) regardless of the command signal input.

The feedback potentiometer should be mounted to provide a proper feedback signal through the entire range between the *open* and *closed* positions. For best results, position the actuator to the midway point between the *open* and *closed* positions; then adjust the feedback potentiometer for approximately 5VDC (or 1/2 of the potentiometer's resistance) between GND and WIPER.

Since the feedback potentiometer is crucial for proper operation of the PPL-100R, the following items should be carefully observed:

- 1 - Potentiometer value should be 1K ohms.
- 2 - The potentiometer should be a linear taper type.
- 3 - The potentiometer must be properly wired to provide the correct feedback signal.
- 4 - The potentiometer must be properly and securely mounted to provide a reliable feedback signal.

OUTPUT INDICATORS

The PPL-100R Remote Module provides three on-board indicators. The yellow LED indicates that power from the Command Module is present on the Power Loop. When the open output is turned on, the red LED indicator will turn on, and when the close output is turned on, the green LED indicator will turn on (see Outline). If the actuator reaches its mechanical limit before attaining the position represented by the command signal, the PPL-100R will maintain power to the associated solenoid (open or close), and the associated indicator will be on even though the actuator is not in motion.

LOSS OF COMMAND SIGNAL

When the 1-5V or 4-20mA type command signal is used, the PPL-100C/PPL-101C Command Module can detect that the input signal has been disconnected and then pass that information to the PPL-100R Remote Module. To enable this feature, jumper plug JP2 must be installed on the Command Module. For applications using 0-10V command signals, loss of command cannot be detected; do not install jumper JP2 in these applications.

When using the loss of command feature, the PPL-100R can be configured to respond in one of three ways: turn both outputs off (to shut off the air supply to the actuator, leaving it in its last position), turn on the open output (to move the actuator to the full *open* position), or turn on the close output (to move to the full *closed* position). To select the desired response to a loss of command, install the jumper plug as shown in the Outline information. If the jumper plug is not installed, the PPL-100R will default to the *open* position upon loss of command.

CALIBRATION (Remote Module)

Prior to calibration, the air supply to the actuator must be set to maximum recommended operating pressure, and the flow controls must be set for the desired actuator speed. After insuring that the Power Loop, solenoid valves, and feedback potentiometer are wired to provide a proper feedback signal, as described under "REMOTE MODULE CONNECTIONS", follow these steps to calibrate the units (see Outline for location of the adjustments).

- 1 - Apply AC power to the Command Module, and set the command input signal to minimum:

0V for 0-10V input type
 1V for 1-5V input type
 4mA for 4-20mA input type

- 2 - Verify that the yellow LED on the Remote Module is on; if not, check wiring. Adjust the "Zero" adjustment on the Remote Module so that the actuator moves to the desired *closed* position. If the desired position cannot be achieved, check that the feedback potentiometer provides a feedback signal as described under "REMOTE MODULE CONNECTIONS"; also check that the mechanical limit adjustments on the actuator are not interfering.
- 3 - If the actuator is hunting for position, turn the "Deadband" adjustment on the Remote Module clockwise until the hunting stops. If the actuator is not hunting for position, turn the "Deadband" adjustment counterclockwise until the actuator begins to hunt; then turn the "Deadband" adjustment slightly clockwise until hunting stops.

WARNING! Solenoid failure may occur if the "Deadband" adjustment is set to allow continuous hunting. This can cause excessive wear of solenoids, actuator seals, and feedback potentiometer.

- 4 - Set the command signal input to maximum on the Command Module.

10V for 0-10V input type
 5V for 1-5V input type
 20mA for 4-20mA input type

- 5 - Adjust the "Span" adjustment so that the actuator moves to the desired *open* position. If the desired position cannot be achieved, check the mechanical limit adjustment on the actuator.

NOTE: The "Zero" adjustment is an offset setting rather than an absolute setting. Should the "Zero" adjustment be changed, the "Span" adjustment should be checked for the desired *open* position. Setting of the "Span" adjustment has no effect on the "Zero" adjustment.

- 6 - To check proper operation and linearity, set the command signal to halfway on the Command Module:

5V for 0-10V input type
 3V for 1-5V input type
 12mA for 4-20mA input type

Verify that the actuator's position is midway between the *open* and *closed* positions.

CALIBRATION (Command Module)

The Command Module must be calibrated after the Remote Module has been calibrated, and after the unit has been installed using the preferred wiring. Note, follow the steps for the desired output type, either 0-10V or 4-20mA. Refer to Outline for location of adjustments.

- 1 - Turn off AC power to the Command Module, and set the command input signal to minimum:

0V for 0-10V input type
1V for 1-5V input type
4mA for 4-20mA input type

- 2 - 0-10V Output - Connect the negative lead of a DVM to J2-4 and the positive lead to J2-9; set the DVM for a 20VDC range.

4-20mA Output - Connect the negative lead of a 4-20mA monitor to J2-4 and the positive lead to J2-10.

- 3 - Apply AC power to the Command Module and adjust the "Zero" potentiometer on the Command Module for the following:

0-10V Output - 0 VDC; for proper linearity, turn the adjustment so it just reaches 0VDC.

4-20mA Output - 4 mA

- 4 - Set the command signal input to maximum on the Command Module.

10V for 0-10V input type
5V for 1-5V input type
20mA for 4-20mA input type

- 5 - Adjust the "Span" potentiometer on the Command Module for the following:

0-10V Output - 10 VDC

4-20mA Output - 20 mA

- 6 - Set the command signal to minimum and repeat steps 3 through 5 until zero and span positions yield the desired setting.

REVERSE ACTING CALIBRATION

When converting a direct acting actuator to a reverse acting actuator, two changes in wiring must be made on the PPL-100R:

- 1 - Reverse the feedback potentiometer wires connected to GND and +10V.
- 2 - Swap the open and close solenoids.

NOTE: If only one of the changes is made, the actuator will move to either full open or full closed.

After making the wiring changes, refer to **CALIBRATION** (Remote Module) and (Command Module) for setting the zero and span adjustments.

SPECIFICATIONS

PPL-100R Remote Module

FEEDBACK SIGNAL INPUT

Input Voltage: 0-10VDC
External Feedback Potentiometer: 1K ohms

CONTROL ADJUSTMENTS

Zero: adjustable throughout feedback signal range
Span: adjustable throughout command signal range
Deadband: linearly adjustable throughout signal range

SOLENOID OUTPUTS

24VDC @ 3W maximum (less fail solenoid)

HEAT DISSIPATION

4.8W typical

ENVIRONMENTAL

Operating Temperature Range: -40 °C to 85 °C

Storage Temperature Range: -40 °C to 85 °C

Relative Humidity Range: 0 to 90 % (noncondensing)

SPECIFICATIONS**PPL-100C/PPL-101C Command Modules****POWER REQUIREMENTS**PPL-100C: 117VAC $\pm 10\%$, 50/60 Hz, 20VA maximumPPL-101C: 234VAC $\pm 10\%$, 50/60 Hz, 20VA maximum

Fuse Rating:

PPL-100C: 0.5A Slo-Blo, PCB mounted

PPL-101C: 0.25A Slo-Blo, PCB mounted

COMMAND SIGNAL INPUT

0-10 VDC Input

Input Impedance: 5K ohms

External Command Potentiometer: 1K ohm

1-5 VDC Input

Input Impedance: 1M ohms minimum

Loss of Command Signal Threshold: $\leq 0.75V$

4-20 mA Input

Input Impedance: 255 ohms $\pm 1\%$ *Loss of Command Signal* Threshold: $\leq 3mA$ **FEEDBACK SIGNAL OUTPUTS**

0-10VDC Output: 10mA maximum load

4-20mA Output: 850 ohms maximum load

FEEDBACK SIGNAL ADJUSTMENTS

Zero: adjustable throughout feedback signal range

Span: adjustable throughout command signal range

POWER SUPPLY OUTPUTS

Input Transmitter Power (J2-8): 24VDC @ 20mA max

Command Signal Potentiometer Power (J2-7): 10VDC @ 10mA max

NOTE: Do not connect these outputs to other power supplies.**ENVIRONMENTAL**

Operating Temperature Range: 0 °C to 60 °C

Storage Temperature Range: -40 °C to 85 °C

Relative Humidity Range: 0 to 90 % (noncondensing)

WIRING DIAGRAMS

Input and Output Signal Configurations

