

## ADM-100

24V AC/DC to DC Motor Converter Module

The Peaktronics ADM-100 Series Motor Converter Modules are electronic interface units that allow a 24VDC motor to be powered and controlled in the same manner as a 24VAC split phase motor. Its compact size allows the unit to be mounted inside most DC actuators. The unit has an 8 pin screw terminal strip that provides easy wiring to the DC motor, limit switches, and torque switches. Three of the terminals provide the usual split phase motor connections: *open*, *close*, and *motor neutral*.

The unit allows a 24VDC actuator to directly replace a 24VAC actuator. The unit also features dynamic braking which provides better resolution and control while eliminating the need for a mechanical brake in many applications. The unit can be used in conjunction with other Peaktronics 24VAC control products and mounting kits - this combination allows a complete line of 24VAC actuators to be created from a 24VDC actuator line.

The ADM-100 and ADM-100C can be used with motors with up to 20A locked rotor current, while the ADM-100A and ADM-100B can be used with motors with up to 6A locked rotor current. The ADM-100 and ADM-100A come with two high temperature high strength tie wraps allowing the units to be strapped to the side of the motor which reserves space in the actuator for other controls. The ADM-100 also features two mounting flanges with provisions for screw mounting. The ADM-100B and ADM-100C are more compact and economical and must be mounted to a suitable metal bracket; the unit comes with two screws for direct mounting.

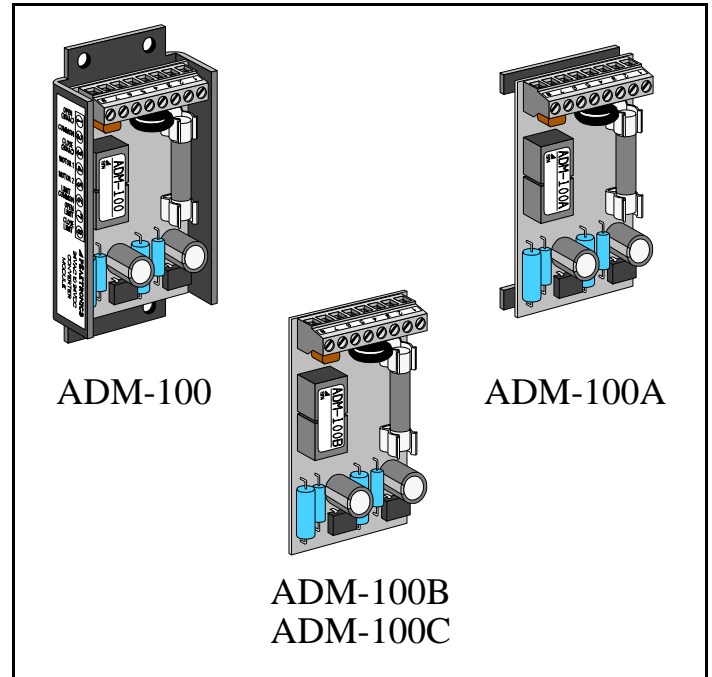

## SPECIFICATIONS

### OPERATING VOLTAGE

20 to 30 VAC  
20 to 30 VDC

### OPERATING CURRENT

Limit Switch Current and Operating Current (typical): 120mA @ 24VAC, 96mA @ 24VDC  
Fuse Type (ADM-100, ADM-100C): 10A (Bussman ABC-10 or Littelfuse 314010)  
Fuse Type (ADM-100A, ADM-100B): 4A (Bussman ABC-4 or Littelfuse 314004)

### DC MOTOR OUTPUTS

Maximum Load Current (ADM-100, ADM-100C): 20A locked rotor for 3 seconds typical  
Maximum Load Current (ADM-100A, ADM-100B): 6A locked rotor for 3 seconds typical

### ENVIRONMENTAL

Operating Temperature 0 to 60 °C  
Storage Temperature -40 to 85 °C  
Relative Humidity 0 to 90 % (non-condensing)

**OUTLINE**

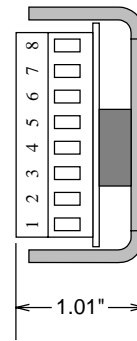
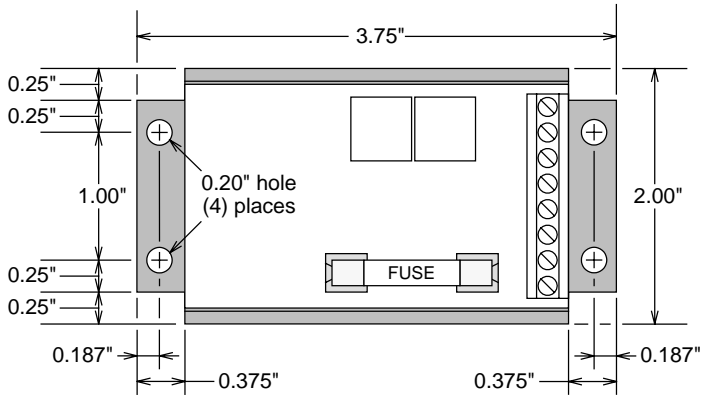

**ELECTRICAL CONNECTIONS**

- 8 CLOSE LIMIT
- 7 OPEN LIMIT
- 6 LIMIT COMMON
- 5 MOTOR 2
- 4 MOTOR 1
- 3 CLOSE (24VAC/DC)
- 2 COMMON
- 1 OPEN (24VAC/DC)

ADM-100

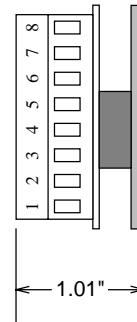
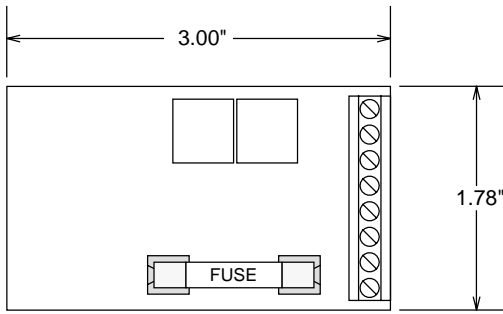

**ELECTRICAL CONNECTIONS**

- 8 CLOSE LIMIT
- 7 OPEN LIMIT
- 6 LIMIT COMMON
- 5 MOTOR 2
- 4 MOTOR 1
- 3 CLOSE (24VAC/DC)
- 2 COMMON
- 1 OPEN (24VAC/DC)

ADM-100A

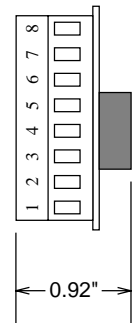
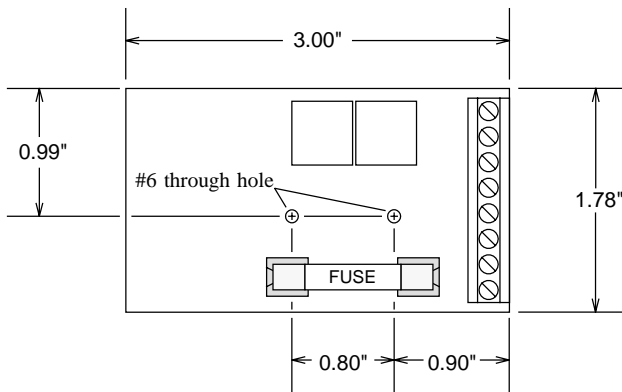

**ELECTRICAL CONNECTIONS**

- 8 CLOSE LIMIT
- 7 OPEN LIMIT
- 6 LIMIT COMMON
- 5 MOTOR 2
- 4 MOTOR 1
- 3 CLOSE (24VAC/DC)
- 2 COMMON
- 1 OPEN (24VAC/DC)

ADM-100B  
ADM-100C

## MOUNTING DIAGRAMS

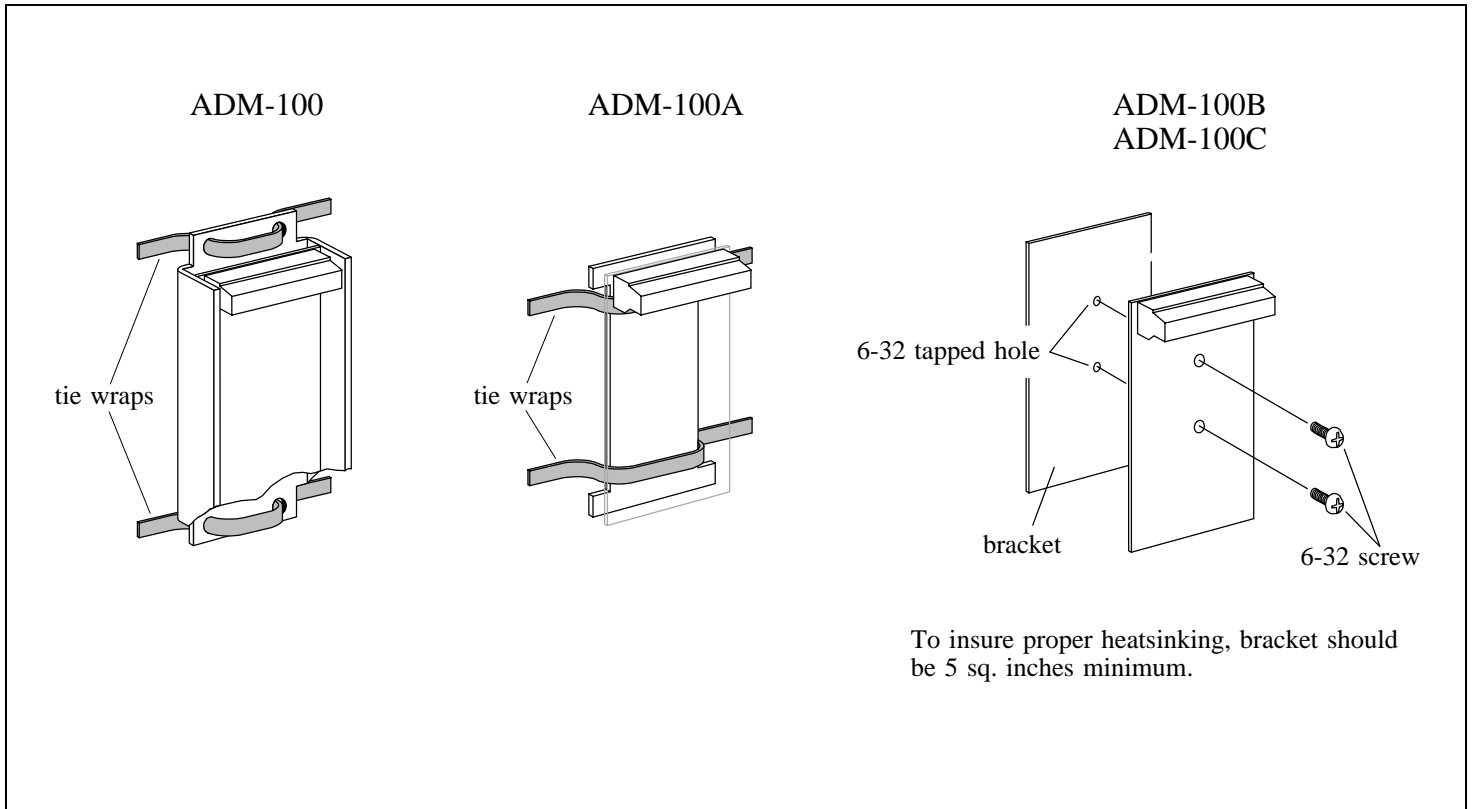

## BLOCK DIAGRAM

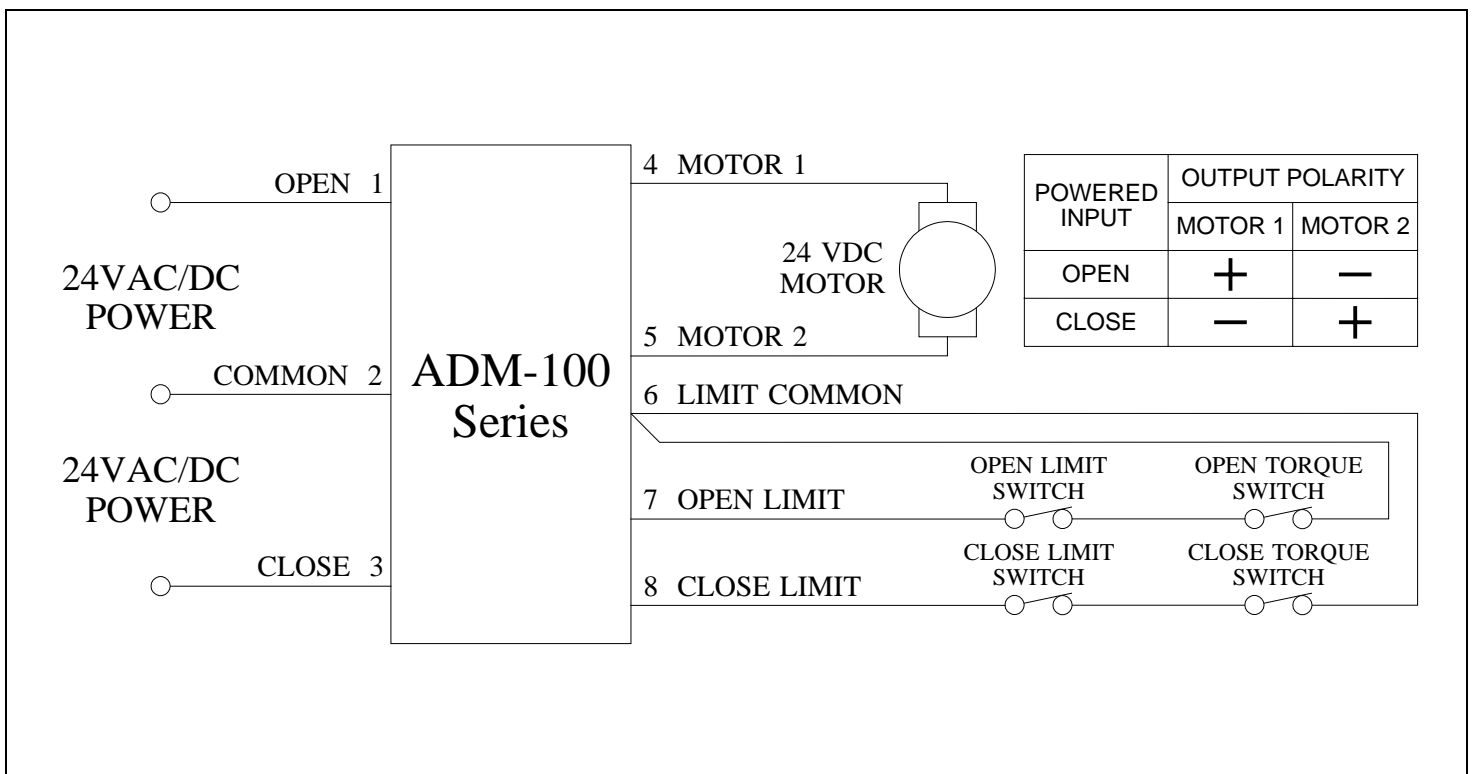

### 24VAC Analog Modulating Actuator using a 24VDC Actuator

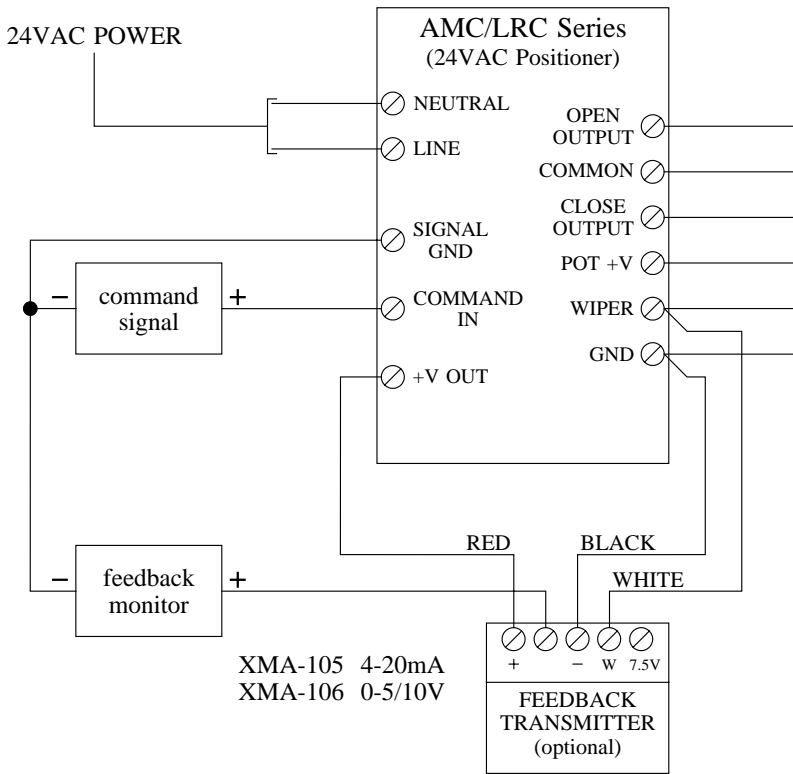

NOTE: Refer to Block Diagram for connections to motor and limit switches.

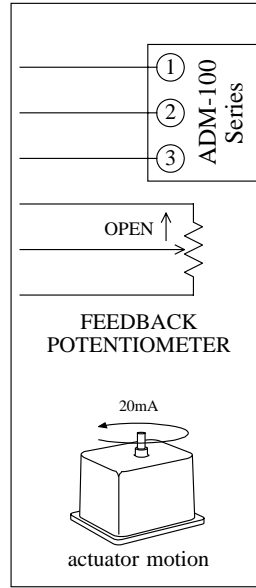

DIRECT ACTING

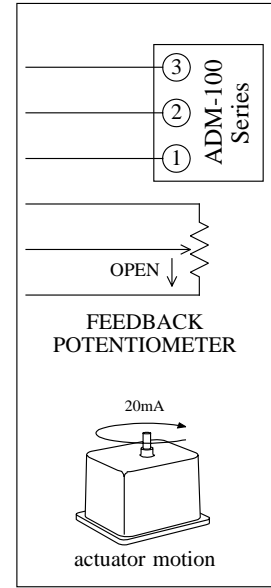

REVERSE ACTING

### 24VAC Digital Modulating Actuator using a 24VDC Actuator

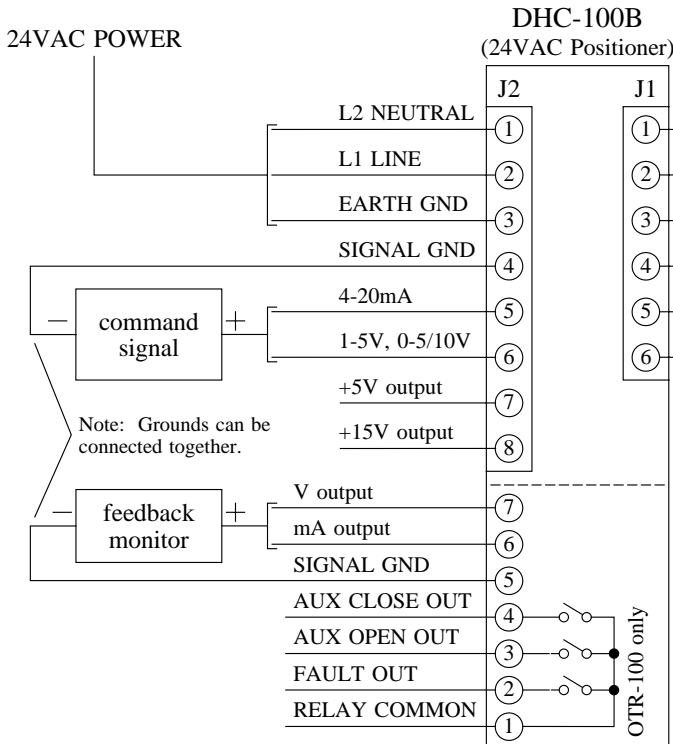

NOTE: Refer to Block Diagram for connections to motor and limit switches.

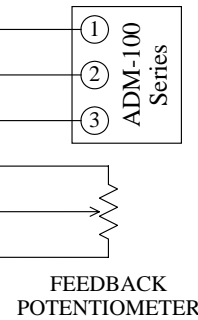

Direct acting or reverse acting is automatically set during calibration of close and open.

OTX-100 Transmitter Module (optional)  
OTR-100 Transmitter/Relay Module (optional)