

## DHC Series Option Module

The Peaktronics OCM-103 Option Module is specifically designed for use with the Peaktronics DHC Series controllers. The module provides an isolated RS-485 bus connection using the Modbus RTU Mode protocol to access the digital parameters in a DHC controller. All connections to the DHC controller are automatically made when the OCM-103 is plugged into the controller (see below).

The on-board screw terminal strip provides easy connection to the bus (terminals A, B, and Common). With an input impedance of 96K ohms, up to 256 units can be connected on the bus. On-board dip switches allow configuring the module for various bus settings: baud rate, parity, node address, and line terminating resistor.

## FEATURES

- Standard RTU mode settings: Even or Odd Parity with 1 Stop Bit, No Parity with 2 Stop Bits
- Non-standard RTU mode setting: No Parity with 1 Stop Bit
- selectable baud rates: 9600, 19.2K, 57.6K, 115.2K
- node address setting: 0 to 255
- selectable line terminating resistor: 150 ohm
- Conditionally compliant with Modbus Protocol

## OCM-103

### Modbus Option Module

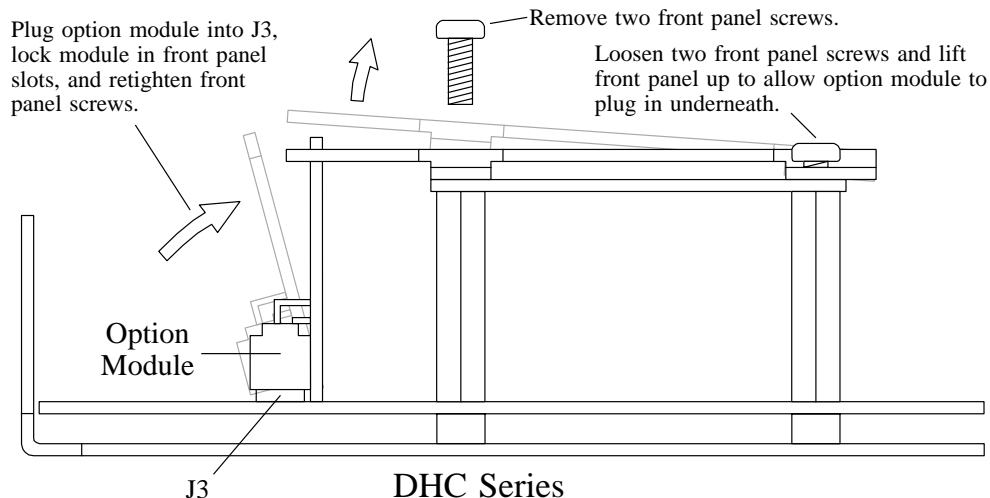
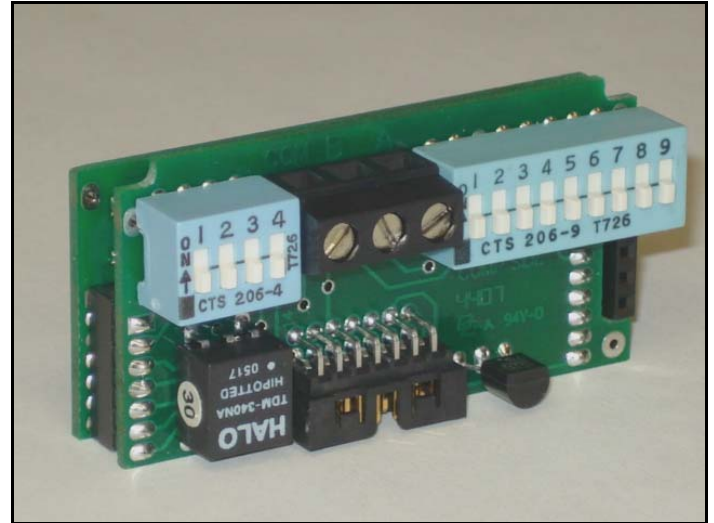

Installing an Option Module

## OUTLINE

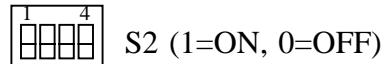
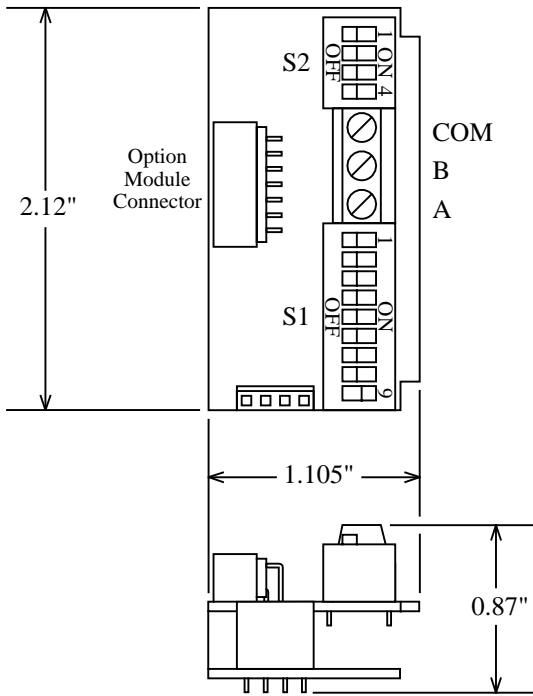

BAUD RATE

- 11 115,200
- 10 57,600
- 01 19,200
- 00 9,600

RTU mode (only)

- 11 No Parity, 1 stop bit
- 10 No Parity, 2 stop bits
- 01 Odd Parity, 1 stop bit
- 00 Even Parity, 1 stop bit

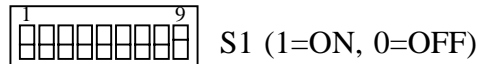

MODBUS ADDRESS (binary)

- S1-2 is most significant bit
- S1-9 is least significant bit

- 1 150 ohm terminating resistor connected
- 0 150 ohm terminating resistor disconnected

## BLOCK DIAGRAM

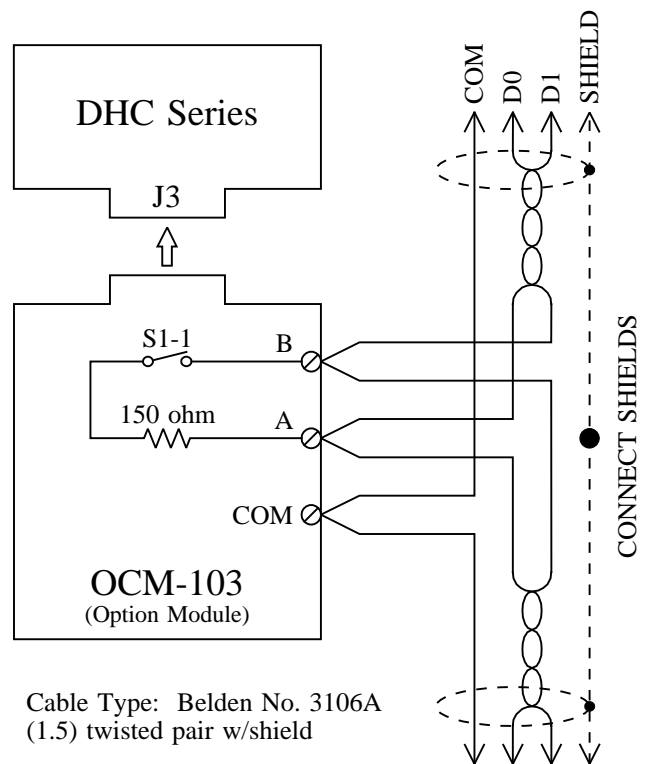
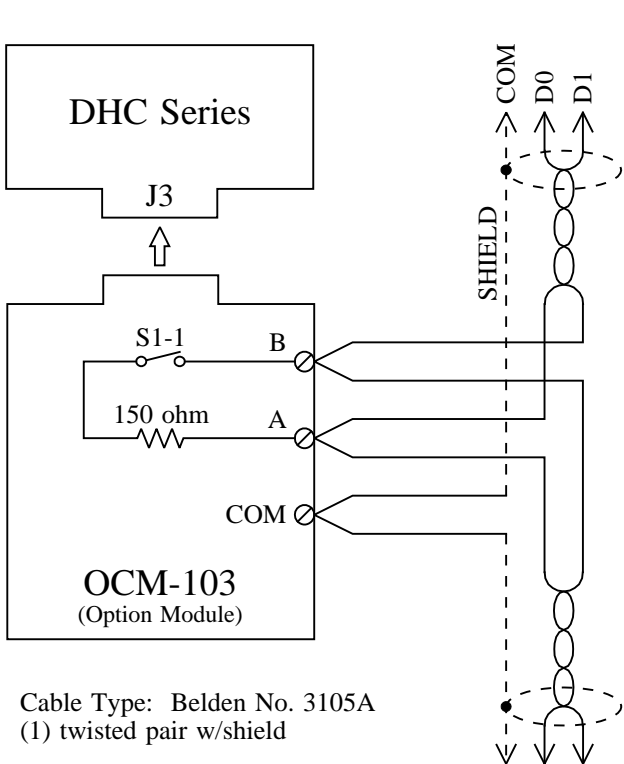

## DESCRIPTION

The OCM-103 plugs into a DHC Series controller, making for easy installation. Power for the OCM-103 and all PACS® communication signals to the DHC controller are made through the Option Module Connector (see OUTLINE). The 3-pin screw terminal strip provides easy field wiring to the bus. S1 is a bank of 9 DIP switches that sets the unit's node address and can optionally connect the internal line terminating resistor. S2 is a bank of 4 DIP switches that configures the unit for the bus.

### MODBUS CONNECTOR

The 3-pin screw terminal strip provides connections to a Modbus Serial Line RS-485 bus. Terminal A corresponds to the D0 Modbus signal, and terminal B corresponds to the D1 Modbus signal. Terminal B is positive in respect to terminal A for a logic "1", and terminal B is negative in respect to terminal A for a logic "0" as shown in Figure 1.

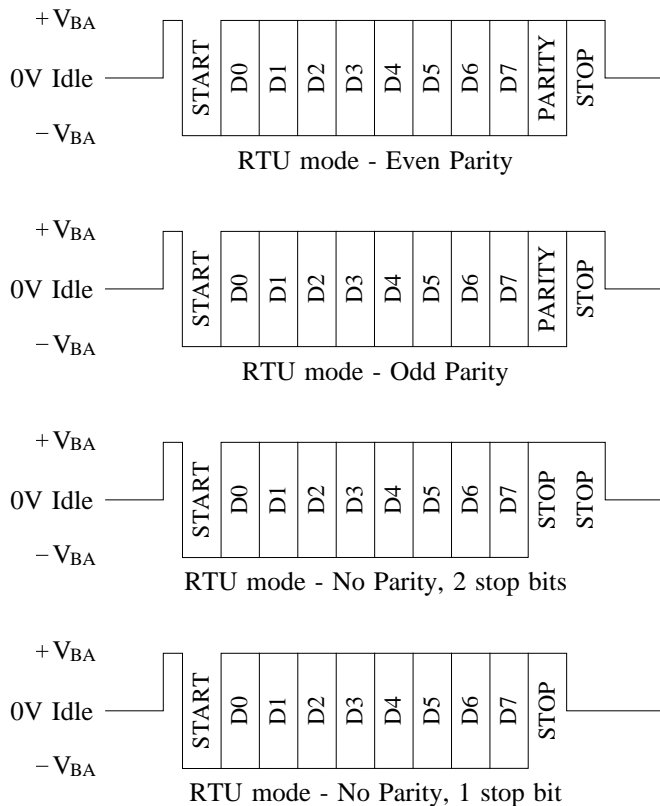

Figure 1 - Bus Timing Diagrams

The COM terminal is the signal common for terminals A and B and must be connected. Note that the bus

connections are electrically isolated, and MUST NOT be connected to the DHC controller's signal ground. The COM terminal must be connected directly to earth ground, preferably at **one point only** for the entire bus; generally, earth ground is connected at the master device.

### S1 - MODBUS ADDRESS and LT RESISTOR

Setting S1-1 to the ON position connects the internal 150 ohm line terminating (LT) resistor between the A and B bus connections. Only units connected at each end of the bus should connect this resistor.

S1-2 to S1-9 set the Modbus node address. The switches represent the binary value of the desired address, where S1-2 is the most significant bit and S1-9 is the least significant bit. The ON position represents a logic "1", while the OFF position represents a logic "0".

The standard Modbus protocol reserves address 0 (all switches OFF) for broadcast commands. Also, addresses 248 to 255 (switch settings 1111000 to 1111111) are reserved by the Modbus organization. Setting the switches to any of these addresses disables the OCM-103, which essentially removes the unit from the bus. If the address switches are changed while the bus is active, the OCM-103 will terminate any Modbus sequence in progress before accepting the new switch settings.

### S2 - BAUD RATE and PARITY

When Even Parity is selected, the parity bit (see Figure 1) should be "0" when the number of "1" bits in a given 8-bit byte is an even number. For an odd number of "1" bits, the parity bit should be "1". Selecting Odd Parity, the parity bit is "0" when the number of "1" bits is an odd number, and the parity bit is "1" for an even number of "1" bits. If the OCM-103 receives an incorrect parity bit value, no response will be given to the received command.

When No Parity is selected, the parity bit is set to a logic "1" representing a *stop* bit. A second *stop* bit can also be selected, which is a standard Modbus setting - see Figure 1 for details. If the OCM-103 receives a logic "0" in the parity position, no response will be given.

Refer to OUTLINE for the available Baud Rate and Parity settings. If any of the S2 switches are changed while the bus is active, the OCM-103 will terminate any Modbus sequence in progress before accepting the new switch settings.

## FUNCTIONAL DESCRIPTION

The OCM-103 is a Modbus slave device addressable from 1 to 247. The OCM-103 communicates to the DHC controller via a PACS® Master port on the Option Module Connector (see OUTLINE). All connections and settings are automatically made when the OCM-103 is plugged into the DHC controller. The OCM-103 supports the functions listed below - all other functions are invalid and invoke an error response from the OCM-103. Refer to the specific section for details on each function.

\$03	Read Holding Registers
\$06	Write Single Register
\$08	Diagnostics
\$41	PACS® (user defined)

The DHC controller is a PACS® Slave that is accessible using PACS® commands (see Appendix B) with the user defined function \$41 (65 decimal), and is referred to here as the PACS® function. Upon receiving a function \$41 command, the OCM-103 switches operation to a gateway that allows the user to directly communicate to the DHC controller.

Upon receiving a function \$03 or \$06 command, the OCM-103 switches operation to a Modbus interface. In this mode of operation, the OCM-103 maintains a virtual image of the DHC controller's parameters that allows fast access to these parameters using conventional Modbus commands. On power up, the OCM-103 defaults to the Modbus interface mode of operation.

Function \$08 is strictly diagnostic and actually communicates to the OCM-103 rather than the DHC controller. Function \$08 does not switch the mode of operation previously set by functions \$03, \$06, or \$41.

### PACS® MASTER

The OCM-103 PACS® Master port communicates to the DHC controller's PACS® Slave port through the Option Module Connector. The OCM-103 maintains an off line timer that allows the DHC controller a limited amount of time to respond; this timer is set to 200msec when the OCM-103 powers up. If the OCM-103 detects an off line time out, it will send an error response with exception code \$0B.

The off line timer value can be changed using Modbus Function \$06 (Write Single Register). However, the changed value is lost if the OCM-103 loses power, and the value will need to be set again after power returns. To monitor the off line timer setting, the value can be read using Modbus Function \$03 (Read Holding Registers).

### MODBUS PROTOCOL

The Modbus Protocol provides that only one master unit be connected to the bus. The master will always initiate any communications taking place on the bus, where the master issues a command (the Modbus Function) and then waits for the appropriate slave device, such as an OCM-103, to respond back. In the event the slave cannot or does not respond, the master will limit the amount of time to wait for a response, at which point it may initiate a new command to another slave.

To avoid conflicts on the bus, the master must allow a sufficient amount of time for the slave to perform its task and respond. When using the PACS® function \$41, the OCM-103 will give a response within the PACS® off line timer value (see PACS® MASTER). When an initial off line time out is detected, a \$0B exception response will be given at the end of the time out period. Once an off line time out is detected, the error response will be immediately given to subsequent requests from the bus until the OCM-103 corrects the detected PACS® error.

When using functions \$03, \$06, and \$08, the OCM-103 will provide an immediate response regardless of when an off line time out is detected. Once a time out is detected, a \$0B exception response is returned until the OCM-103 corrects the detected PACS® error. Function \$08 is not effected by a PACS® off line time out and will not return a \$0B exception response.

Information on the bus is sent as a group of bytes (refer to Figure 1). For the Modbus RTU Mode, one byte consists of a start bit, 8 data bits (least significant bit sent first), a parity bit, and a stop bit. If No Parity is selected, the parity bit is replaced with a stop bit, and a second stop bit may follow if the two stop bit selection is made.

### APPLICATION DATA UNIT (ADU)

The command from the master, and the subsequent response from the slave, consists of a group of bytes called the Application Data Unit, or ADU. The ADU is divided into four fields and is transmitted from left to right in the diagram below:

Address	Function	Data	CRC
---------	----------	------	-----

The master initiates a command by first sending the 8-bit **Address** value of the desired slave unit. This is followed by an 8-bit **Function** code, which commands the slave to perform a specific task, and has a value of 0 to 127 (0 to \$7F hexadecimal) - the most significant bit is

always logic "0". The **Data** field may consist of any number of bytes. The **Function** specifies how many (if any) data bytes will follow. The **CRC** field is error checking bytes that have a value calculated from the values of the preceding bytes of the ADU.

Upon receiving the ADU, the slave will calculate the CRC and compare it to the CRC value received. If the calculated value does not match the received value, the slave will ignore the ADU and will not return a response. If the CRC values match, the slave processes the received command and returns an ADU to the master in the same configuration shown before.

The slave responds by sending back its **Address**, followed by the **Function** (as received from the master), followed by any **Data** (if any) associated with the function, and ending with a **CRC** value calculated from the values in the returning ADU.

If the slave cannot process the function received from the master, it will return an Error Response. In this case, the **Function** value is returned with its most significant bit set to a logic "1". The **Data** will be an 8-bit value representing an Exception Code. Exception Codes returned by the OCM-103 are as follows:

- \$01 **Function** is not supported by the OCM-103.
- \$03 **Data** does not fit with function. Either the values are incorrect, or the number of data bytes is incorrect.
- \$0B PACS<sup>®</sup> Slave connected to the OCM-103 did not respond, or a PACS<sup>®</sup> error was detected by the OCM-103.

If the received **Address** is equal to 0, representing a broadcast command, then the slave will process the command, but will not return a response. What task the slave performs in response to a broadcast command depends on the slave device and the **Function** received in the broadcast command.

The information in an ADU is transmitted on the bus in RTU Mode (Remote Terminal Unit) only. The OCM-103 does not support the ASCII Mode. The following sections describe the RTU mode and the Modbus functions supported by the OCM-103.

## RTU MODE

In the RTU Mode, each byte is a sequence of 11 bits consisting of one start bit, 8 data bits, one parity bit, and one stop bit (see Figure 1). The time required for the 11 bit sequence is referred to as *one character period*, and is symbolized as **t1**. Since the baud rate setting dictates the number of bits per second, **t1** will vary dependent on

the baud rate. In this way, time relative to the baud rate is described. For example, **t3.5** refers to the time required for *3.5 character periods*. The non-standard setting for No Parity and 1 stop bit consists of 10 bits rather than 11 bits, however the OCM-103 calculates *character periods* for this setting as 11 bits.

The bus is considered to be idle if no transmission occurs on the bus for **t3.5** or more. The first byte transmitted on the bus after a **t3.5** period will be considered an **Address** byte, which marks the start of an ADU. The remaining bytes of the ADU must follow as a continuous stream with no more than **t1.5** between each byte of the ADU.

If the OCM-103 detects a time longer than **t1.5** between bytes of an ADU, the ADU will be considered invalid, and no response will be given. After detecting this type of error, the OCM-103 will then wait for a **t3.5** idle period before accepting a new ADU. This means that any delinquent bytes of the error ADU are also ignored.

After receiving the **Address** byte, the second byte received will represent the **Function**. The number of **Data** bytes and what they represent is defined by the specific **Function** - refer to the appropriate section for details on the specific function. Following the **Data** bytes, two **CRC** bytes are received with the least significant byte received first. Refer to CRC CALCULATION for details on how the CRC bytes are calculated.

Once the OCM-103 detects the start of an ADU, it will accept all bytes until it detects a bus idle for **t3.5** periods. At that time, the OCM-103 will process the received ADU if the received **Address** byte matches the address setting on S1. The ADU is also processed if the received **Address** is 0 (broadcast command), but no response will be given.

## FUNCTION \$03 - Read Holding Registers

Function \$03 is used to read a number of contiguous registers in a Modbus slave unit, where each register has a specific 16 bit (2 bytes) address and contains a 16 bit value. After sending the **Function** byte (\$03), the Modbus master sends the **Starting Register Address** (most significant byte first). This is followed by a 2-byte value (most significant byte first) that specifies the **Number of Registers** to be returned by the slave. The number of registers that can be requested must be a number from 1 to 125 (\$7D); this means that the most significant byte is always zero.

The Modbus slave responds by returning the **Function** byte (\$03) followed by a one byte value indicating the **Number of Bytes** being returned. This is followed by pairs of bytes (most significant byte first) representing the data contained in each requested register, starting with the requested starting register address. Since the register

data is two bytes, the **Number of Bytes** being returned is always twice the value of the **Number of Registers** being requested.

The OCM-103 provides 24 readable registers (Register Addresses \$0000 to \$0017) that are specific to the DHC Series controller; refer to the "Modbus User's Guide - DHC Series Controllers with OCM-102" manual for complete details; the OCM-103 operates exactly the same as the OCM-102 except that the OCM-102 also supports the ASCII Mode.

An error response with exception code \$03 is returned if the **Starting Register Address** is greater than \$0017, or if the **Number of Registers** requested results in a **Register Address** that is greater than \$0017.

Typical Function \$03 ADU sequence:

### Modbus Master Request

Function	03
Starting Register Address	<i>aa aa</i>
Number of Registers	00 <i>nn</i>

### OCM-103 Response

Function	03
Number of Bytes	<i>bb</i> ( <i>bb</i> = 2 times <i>nn</i> )
Data	<i>xx xx</i>

Register Address \$0000 is the OCM-103 PACS® Off Line Timer Value (see PACS® MASTER). The most significant byte of the returned **Data** is always zero. The least significant byte represents the PACS® Master off line time out period in 0.1 second increments. So, a value of 26 (\$1A) indicates a time out period of 2.6 seconds. On power up, the OCM-103 automatically sets the Off Line Timer Value to 2 (0.2 seconds). To set a different value after power up, use Function \$06.

## FUNCTION \$06 - Write Single Register

Function \$06 is used to change the value contained in a given register. After sending the **Function** byte (\$06), the Modbus master sends the **Register Address** (most significant byte first) followed by the 2-byte **Data** (most significant byte first) that is to replace the contents of the specified register. The Modbus slave responds by returning the same ADU to confirm that the change was made.

Of the 24 readable registers, Register Addresses \$0000 to \$0005 can be written. When writing Register Address \$0000 (OCM-103 PACS® Off Line Timer Value), the most significant byte of the **Data** must be zero; if not, an error response with exception code \$03 is returned. If the **Register Address** is greater than \$0005, exception code \$03 is also returned.

Typical Function \$06 ADU sequence:

### Modbus Master Request

Function	06
Register Address	<i>aa aa</i>
Data	<i>xx xx</i>

### OCM-103 Response

Function	06
Register Address	<i>aa aa</i>
Data	<i>xx xx</i>

## FUNCTION \$08 - Diagnostics

Function \$08 is used for diagnostics and control of the Modbus slave device. This function operates on the OCM-103 rather than the DHC Controller that is connected to the OCM-103. After sending the **Function** byte (\$08), the Modbus master sends a 2-byte (most significant byte first) **Subfunction** code. This is followed by any **Data** associated with the subfunction.

The OCM-103 supports a limited number of subfunctions listed below:

\$0000	Return Query Data
\$0001	Restart Communications Option
\$0004	Force Listen Only Mode

All other subfunctions invoke an error response with exception code \$03. Each subfunction is described below.

### Subfunction \$0000 - Return Query Data

Following the **Subfunction** code (\$0000), 2-bytes of **Test Data** are sent. The Modbus slave responds by returning the same ADU to confirm that the **Test Data** was properly received.

### Modbus Master Request

Function	08
Subfunction	00 00
Test Data	<i>xx xx</i>

### OCM-103 Response

Function	08
Subfunction	00 00
Test Data	<i>xx xx</i>

### Subfunction \$0001 - Restart Communications Option

Subfunction \$0001 is used to restart a Modbus slave device which is intended to clear various diagnostic counters and registers. The OCM-103 does not maintain or support such counters and registers. Specific to the OCM-103, this subfunction is used to bring the OCM-103 out of the Listen Only Mode (see Subfunction \$0004).

Following the **Subfunction** code (\$0001), 2-bytes of **Test Data** are sent. The most significant byte (sent first) of the **Test Data** must be either \$00 or \$FF - any other value invokes an error response with an exception code of \$03. Normally, \$FF commands the slave to clear its event log, while \$00 commands the slave to retain its event log. The OCM-103 does not maintain an event log, and either value is accepted.

If the Modbus slave is not in the Listen Only Mode, it responds by returning the same ADU to confirm that the **Test Data** was properly received. If the slave was in the Listen Only Mode, no response is given, but the Listen Only Mode is deactivated starting with the next ADU received.

#### Modbus Master Request

Function	08
Subfunction	00 01
Test Data	xx 00

#### OCM-103 Response

Function	08
Subfunction	00 01
Test Data	xx 00

### Subfunction \$0004 - Force Listen Only Mode

Subfunction \$0004 is used to put a Modbus slave device into the Listen Only Mode which basically removes the device from the bus. The slave will continue monitoring the bus, merely waiting for Subfunction \$0001, which reactivates the slave.

Following the **Subfunction** code (\$0004), 2-bytes of **Data** are sent. The **Data** must be \$0000 - any other value invokes an error response with an exception code of \$03. Provided that the **Data** is \$0000, the slave enters the Listen Only Mode and no response is given.

#### Modbus Master Request

Function	08
Subfunction	00 04
Data	00 00

#### OCM-103 Response

NO RESPONSE GIVEN

The OCM-103 is essentially turned off by Subfunction \$0004, and then turned back on by Subfunction \$0001. While in the Listen Only Mode, the OCM-103 puts its PACS<sup>®</sup> Master port in an off line state. In this state, the DHC Controller's PACS<sup>®</sup> timer will expire, causing it to detect a loss of communications.

### FUNCTION \$41 - PACS<sup>®</sup> (user defined)

Function \$41 is a Modbus user defined function, and its operation described here is specific to the OCM-103. Function \$41 is used to send PACS<sup>®</sup> commands to the PACS<sup>®</sup> Slave connected to the OCM-103. After sending the **Function** byte (\$41), the Modbus master sends the hexadecimal byte values that make up a **PACS<sup>®</sup> Command**, which can vary from 1 to 8 bytes in length. Some PACS<sup>®</sup> commands return requested data, which can be 1, 2, or 4 bytes in length.

The OCM-103 responds by returning the **Function** byte (\$41) followed by the returned **Data** bytes, if any. If no data bytes are returned, the **CRC** bytes immediately follow the **Function** byte.

Each PACS<sup>®</sup> command specifies an exact number of bytes that make up the command string as well as the number of bytes to be returned. If the command string does not contain the correct number of bytes, the OCM-103 returns an error response with exception code \$03. For a list of PACS<sup>®</sup> commands, see Appendix B. For complete details on the PACS<sup>®</sup> protocol and commands, refer to "The PACS<sup>®</sup> Standard" manual, which is available from Peaktronics.

"The PACS<sup>®</sup> Standard" manual describes an ASCII mode for PACS<sup>®</sup> commands, which should not be confused with the ASCII mode setting for Modbus. The PACS<sup>®</sup> ASCII format can only be used with devices that incorporate an ASCII translator that converts the ASCII strings to their corresponding hexadecimal bytes - the OCM-103 does not have such a translator.

The PACS<sup>®</sup> protocol is a set of universal commands for sending or requesting data. The specific PACS<sup>®</sup> Slave device determines what the data represents and how it is used. Refer to the "Modbus User's Guide" for the particular PACS<sup>®</sup> Slave device being used.

### CRC CALCULATION (RTU MODE)

Cyclical Redundancy Checking (CRC) is used in the RTU mode to provide a means for checking a received ADU for errors. The CRC value is a 16 bit binary number represented by two bytes. The two CRC bytes are always the last two bytes of an ADU, where the least significant byte (LSB) is sent first, and the most significant byte

(MSB) is sent last. For example, if the 16 bit CRC value is \$5850, the \$50 LSB is sent first and then followed by the \$58 MSB. Therefore, \$58 is the last byte of the ADU.

The CRC value is initially set to \$FFFF. Then each byte of the ADU, starting with the **Address** byte, is used to modify the CRC value in the manner described below:

1. Exclusive OR the LSB of the CRC value with the ADU byte being processed, and replace the CRC LSB with the result.
2. If the least significant bit of the new CRC value is "0", shift the 16 bit CRC value one bit to the right, setting the most significant bit to "0".

If the least significant bit of the new CRC value is "1", shift the 16 bit CRC value one bit to the right, setting the most significant bit to "0". Then exclusive OR the shifted 16 bit CRC value with the 16 bit constant \$A001, and replace the CRC value with the result.

3. Repeat step 2 seven times.

The modified CRC value resulting from the above, is then further modified in the same way by each of the remaining bytes of the ADU. The following example illustrates the calculation.

## Modbus Master Requesting ADU

05 41 1C 50 58

where: \$05 is slave **Address 5**  
 \$41 is PACS<sup>®</sup> **Function**  
 \$1C is PACS<sup>®</sup> LEVEL command  
 \$5850 is CRC value

The CRC value is calculated as follows:

\$FFFF initial CRC value  
 \$437F modify CRC with \$05  
 \$D0C2 further modify CRC with \$41  
 \$5850 further modify CRC with \$1C

## OCM-103(address 5) Responding ADU

05 41 01 90 51

where: \$05 is slave **Address 5**  
 \$41 is PACS<sup>®</sup> **Function**  
 \$01 is level of PACS<sup>®</sup> Slave  
 \$5190 is CRC value

The CRC value is calculated as follows:

\$FFFF initial CRC value  
 \$437F modify CRC with \$05  
 \$D0C2 further modify CRC with \$41  
 \$5190 further modify CRC with \$01



## SPECIFICATIONS

### BUS CONNECTION

Type: ANSI TIA/EIA RS-485A (electrically isolated up to 1500 V<sub>RMS</sub>)

Protocol:

Modbus RTU Mode (only)

Logic "1": +V<sub>BA</sub>

Logic "0": -V<sub>BA</sub>

Selectable Address: 0 to 255 (1 to 247 usable)

Selectable Line Terminating Resistor (R<sub>BA</sub>): 150 ohm

Line Polarization: not required

BAUD RATE	RTU mode character periods	
	t1.5 (usec)	t3.5 (usec)
9600	1,719	4,010
19.2K	859	2,005
57.6K	286	668
115.2K	143	334

### CABLE CHARACTERISTIC IMPEDANCE

A value of 100 ohms or greater may be preferred, especially for 19.2K and higher baud rates.

### TRANSMITTER OUTPUT

Differential Output Voltage (V<sub>BA</sub>):

5V max @ no load

1.5V min @ 54 ohm load

Output Short Circuit Current:

A to B: 95mA typical

A or B to COM: 113mA typical

### TRANSMITTER INPUT

Input Impedance (R<sub>BA</sub>): 96K ohms min (1/8 node)

Input Logic Threshold Voltage (V<sub>BA</sub>): 30mV min, 200mV max

Input Hysteresis: 20mV typical

### ENVIRONMENTAL

Operating Temperature Range: 0 °C to 60 °C

Storage Temperature Range: -40 °C to 85 °C

Relative Humidity Range: 0 to 90 % (noncondensing)



## APPENDIX A - ASCII Conversion Table

HEX	BINARY	ASCII	HEX	BINARY	ASCII	HEX	BINARY	ASCII
00	0000 0000	NUL	2B	0010 1011	+	55	0101 0101	U
01	0000 0001	SOH	2C	0010 1100	,	56	0101 0110	V
02	0000 0010	STX	2D	0010 1101	-	57	0101 0111	W
03	0000 0011	ETX	2E	0010 1110	.	58	0101 1000	X
04	0000 0100	EOT	2F	0010 1111	/	59	0101 1001	Y
05	0000 0101	ENQ				5A	0101 1010	Z
06	0000 0110	ACK	30	0011 0000	0	5B	0101 1011	[
07	0000 0111	BEL	31	0011 0001	1	5C	0101 1100	\
08	0000 1000	BS	32	0011 0010	2	5D	0101 1101	]
09	0000 1001	TAB	33	0011 0011	3	5E	0101 1110	^
0A	0000 1010	LF	34	0011 0100	4	5F	0101 1111	_
0B	0000 1011	VT	35	0011 0101	5			
0C	0000 1100	FF	36	0011 0110	6	60	0110 0000	\
0D	0000 1101	CR	37	0011 0111	7	61	0110 0001	a
0E	0000 1110	S0	38	0011 1000	8	62	0110 0010	b
0F	0000 1111	S1	39	0011 1001	9	63	0110 0011	c
			3A	0011 1010	:	64	0110 0100	d
10	0001 0000	DEL	3B	0011 1011	;	65	0110 0101	e
11	0001 0001	DC1	3C	0011 1100	<	66	0110 0110	f
12	0001 0010	DC2	3D	0011 1101	=	67	0110 0111	g
13	0001 0011	DC3	3E	0011 1110	>	68	0110 1000	h
14	0001 0100	DC4	3F	0011 1111	?	69	0110 1001	i
15	0001 0101	NAK				6A	0110 1010	j
16	0001 0110	SYN	40	0100 0000	@	6B	0110 1011	k
17	0001 0111	ETB	41	0100 0001	A	6C	0110 1100	l
18	0001 1000	CAN	42	0100 0010	B	6D	0110 1101	m
19	0001 1001	EM	43	0100 0011	C	6E	0110 1110	n
1A	0001 1010	SUB	44	0100 0100	D	6F	0110 1111	o
1B	0001 1011	ESC	45	0100 0101	E			
1C	0001 1100	FS	46	0100 0110	F	70	0111 0000	p
1D	0001 1101	GS	47	0100 0111	G	71	0111 0001	q
1E	0001 1110	RS	48	0100 1000	H	72	0111 0010	r
1F	0001 1111	US	49	0100 1001	I	73	0111 0011	s
			4A	0100 1010	J	74	0111 0100	t
20	0010 0000	SP	4B	0100 1011	K	75	0111 0101	u
21	0010 0001	!	4C	0100 1100	L	76	0111 0110	v
22	0010 0010	"	4D	0100 1101	M	77	0111 0111	w
23	0010 0011	#	4E	0100 1110	N	78	0111 1000	x
24	0010 0100	\$	4F	0100 1111	O	79	0111 1001	y
25	0010 0101	%				7A	0111 1010	z
26	0010 0110	&	50	0101 0000	P	7B	0111 1011	{
27	0010 0111	'	51	0101 0001	Q	7C	0111 1100	
28	0010 1000	(	52	0101 0010	R	7D	0111 1101	}
29	0010 1001	)	53	0101 0011	S	7E	0111 1110	~
2A	0010 1010	*	54	0101 0100	T	7F	0111 1111	DEL

## APPENDIX B - PACS® Reference Guide

	PACS® CODE	ASCII	DATA MODE	ADDR MODE		PACS® CODE	ASCII	DATA MODE	ADDR MODE
<b>A</b> ADD	64	ASa,d	SING	DIR	<b>L</b> LEVEL	1C	L	SING	
	84	ADa,d	DOUB	DIR					
	C4	AQa,d	QUAD	DIR					
	25	AS,d	SING	IND					
	45	AD,d	DOUB	IND					
	85	AQ,d	QUAD	IND	<b>OR</b> OR	6A	ORSa,d	SING	DIR
<b>AN</b> AND	68	ANSa,d	SING	DIR		8A	ORDa,d	DOUB	DIR
	88	ANDa,d	DOUB	DIR		CA	ORQa,d	QUAD	DIR
	C8	ANQa,d	QUAD	DIR		2B	ORS,d	SING	IND
	29	ANS,d	SING	IND		4B	ORD,d	DOUB	IND
	49	AND,d	DOUB	IND	8B	ORQ,d	QUAD	IND	
	89	ANQ,d	QUAD	IND	<b>R</b> READ	50	RSa,#	SING	DIR
<b>C</b> CHANGE	62	CSa,d	SING	DIR		51	R#a,#	DOUB	DIR
	82	CDa,d	DOUB	DIR		52	RQa,#	QUAD	DIR
	C2	CQa,d	QUAD	DIR		10	RS,#	SING	IND
	23	CS,d	SING	IND		11	R#,#	DOUB	IND
	43	CD,d	DOUB	IND	12	RQ,#	QUAD	IND	
	83	CQ,d	QUAD	IND	<b>S</b> SUB	66	SSa,d	SING	DIR
<b>D</b> DECR	58	DSa	SING	DIR		86	SDa,d	DOUB	DIR
	59	DDa	DOUB	DIR		C6	SQa,d	QUAD	DIR
	5A	DQa	QUAD	DIR		27	SS,d	SING	IND
	18	DS	SING	IND		47	SD,d	DOUB	IND
	19	DD	DOUB	IND	87	SQ,d	QUAD	IND	
	1A	DQ	QUAD	IND	<b>NOP</b>	00	no ASCII		
<b>EO</b> EX OR	6C	EOSa,d	SING	DIR		03	no ASCII		
	8C	EODa,d	DOUB	DIR		05	no ASCII		
	CC	EOQa,d	QUAD	DIR		07	no ASCII		
	2D	EOS,d	SING	IND		09	no ASCII		
	4D	EOD,d	DOUB	IND		0B	no ASCII		
	8D	EOQ,d	QUAD	IND		0D	no ASCII		
						FF	no ASCII		
<b>I</b> INCR	54	ISa	SING	DIR		3C	0-255		
	55	IDa	DOUB	DIR		3D	256-511		
	56	IQa	QUAD	DIR	3E	512-767			
	14	IS	SING	IND	3F	768-1023			
	15	ID	DOUB	IND	<b>T</b> TIER	5C	Tt,x (channels 0-255)		
	16	IQ	QUAD	IND		5D	Tt,x (channels 256-511)		
<b>x</b> CHAN ID						5E	Tt,x (channels 512-767)		
						5F	Tt,x (channels 768-1023)		