

The Peaktronics APC-100 AC Positioning Calibrator is a bench top unit for calibrating the Peaktronics AMC-100/101, LRC-101 series, and SVC-100 series positioning controllers. The unit includes a feedback potentiometer meter, 4-20mA generator, and 4-20mA digital input/feedback meter.

The APC-100 plugs into a standard 117VAC wall outlet and comes with an adaptor plug (on back of unit) for calibrating 117VAC positioners. By installing the appropriate voltage converter module, positioners with other voltage requirements can also be calibrated.

back of a VCM-102 Voltage Converter Module – be sure to observe polarity. Connect the 8 position plug cable from the APC-100 to the short 8 position socket cable on the back of the VCM-102 – be sure to observe polarity. Set the voltage selector switch to either 12VDC or 24VDC as required by the positioner. The VCM-102 is rated up to 12A running current at 12VDC, or up to 6A running current at 24VDC.

### INSTALLING VOLTAGE CONVERTER MODULE

Disconnect power to the APC-100 by unplugging the power cord, then install the desired voltage converter module as described below.

- **117VAC** – Install the adaptor plug provided with the APC-100 into the back of the unit (rated up to 5A running current).
- **24VAC** – Replace the adaptor plug with a VCM-100 Voltage Converter Module (rated up to 5A).
- **234VAC** – Replace the adaptor plug with a VCM-101 Voltage Converter Module (rated up to 2A).
- **12/24VDC** – Install the adaptor plug provided with the APC-100. Connect the 6 position socket cable from the APC-100 to the short 6 position plug on the

### CALIBRATING LIMIT SWITCHES

1. For AC powered actuators, connect the 6 position socket to the actuator's 6 position connector - be sure to observe polarity.
2. For DC powered actuators, connect the 8 position socket on the VCM-102 to the actuator's 8 position plug - be sure to observe polarity.
3. Plug the APC-100 into a standard 117VAC outlet, and turn on the lighted power switch.
4. Use the CLOSED/OPEN switch to run actuator to the end of its limit positions, then set limit switch cams accordingly. NOTE: when running open or closed, the actuator should be moving in the proper direction; if not, reverse the motor wires.

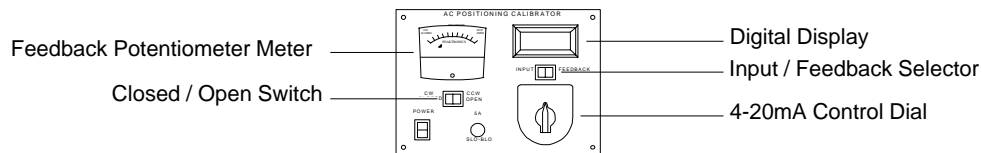

CONTROL PANEL

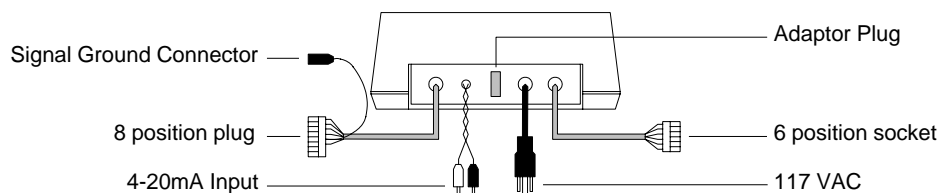

BACK PANEL

## SETTING FEEDBACK POTENTIOMETER

1. Use the CLOSED/OPEN switch to run the actuator to mid-position.
2. Loosen set screw(s) on output shaft gear or mechanism, then turn the gear or mechanism to obtain a "MID-STROKE" reading on the Feedback Potentiometer Meter. NOTE: when running the actuator toward the open position, the meter should move toward the "CCW OPEN" reading; if not, reverse the feedback potentiometer wires.
3. Tighten set screw(s), and turn power off.

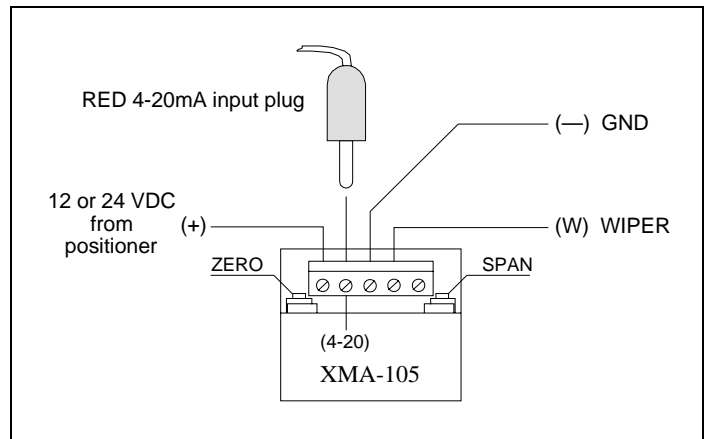

**Figure 1**

## ZERO AND SPAN ADJUSTMENTS

1. For AC powered actuators, connect the 8 position plug to the positioner's 8 position connector, and turn power on.
2. For DC powered actuators, connect the 10 position plug on the VCM-102 to the positioner's 10 position connector, and turn power on.
3. If the actuator hunts or does not move, refer to the manual for the positioner being calibrated.
4. Set the INPUT/FEEDBACK selector to INPUT.
5. Turn the 4-20mA CONTROL DIAL to "0"; the digital display should read "4.00" mA.
6. Adjust the zero adjustment on the positioner to obtain the desired actuator position.
7. Turn 4-20mA CONTROL DIAL to "100"; display should read "19.99" mA.
8. Adjust the span adjustment on the positioner to obtain the desired actuator position.
9. Repeat steps 3 through 8 if necessary, then turn power off.

## XMA-105 TRANSMITTER CALIBRATION

Note that the positioner's zero and span must be calibrated before starting transmitter calibration. Connect the XMA-105 as shown in Figure 1.

1. For AC powered actuators, connect the 8 position plug to the positioner's 8 pin connector.
2. For DC powered actuators, connect the 10 position plug on the VCM-102 to the positioner's 10 position connector.
3. Connect the red 4-20mA input plug to the "4-20" terminal on the XMA-105 (see Figure 1).
4. Set the INPUT/FEEDBACK selector to FEEDBACK.
5. Connect the black 4-20mA input plug to the Signal Ground Connector.
6. Turn power on - the digital display should come on.
7. Turn the 4-20mA CONTROL DIAL to "0" and wait for the actuator to achieve position.
8. Adjust the zero adjustment on the XMA-105 to obtain a reading of "4.00" mA on the display.
9. Turn the 4-20mA CONTROL DIAL to "100" and wait for the actuator to achieve position.
10. Adjust the span adjustment on the XMA-105 to obtain a reading of "19.99" mA on the display.
11. Repeat steps 5 through 10 if necessary, then turn power off.