

▲ PEAKTRONICS

AMI-104

3-Phase Motor Interface

The Peaktronics AMI-104 3-phase Motor Interface is used to interface common electrical control signals to 3-phase actuators. The unit provides the motor control outputs to drive a solid state relay, protection circuits, and isolation between the control inputs and control outputs. A wide range of external control signals can be used to Open and Close the actuator. The unit accepts commonly used 120VAC signals from PLC modules, relay circuits, triac outputs, or solid state relay circuits. Alternatively, signals from a number of electronic sources, including TTL, CMOS, analog drivers, open collector outputs, and low voltage AC outputs, can be used.

The unit has a built-in repeat cycle timer that can be independently enabled or disabled for Open and Close. The timer can be adjusted for 0.1 to 2 seconds "ON" time and for 0.5 to 10 seconds "OFF" time. Since 3-phase motors cannot be switched instantly from open to close operation, the unit provides an adjustable input delay feature.

The unit can be configured for 2-wire or 3-wire control. In 2-wire control, the control signal is applied to the Open input to drive the actuator *open*. When the control signal is removed, or driven to 0V, the actuator will automatically close. In 3-wire control, both control signals (Open and Close) are used to drive the actuator toward *open* or *closed* as desired. When both signals are removed, or driven to 0V, the actuator remains at its last position.

The unit also features a red LED indicator (for the *open* output), a green LED indicator (for the *closed* output), an on-board fuse, two removable screw terminal strips (for easy servicing), and on-board switches to manually open or close the actuator. An auxiliary +24VDC power output (that is isolated from the control signal in-

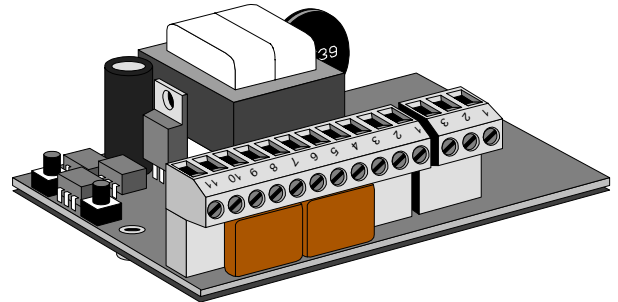

puts) can be used to power a 4-20mA or 0-5/10V transmitter. A transmitter (such as the Peaktronics XMA-105 or XMA-106) can be used to provide a position feedback signal from a feedback potentiometer (such as the Peaktronics POT-102).

The unit comes with standoff mounts and includes an insulating sheet that allows the unit to be mounted directly to the actuator housing or bracket. The unit is rated for 117VAC $\pm 10\%$.

FEATURES

- On/Off Controller for 3-phase actuators.
- Accepts wide range of AC or DC control signals.
- Accepts open collector control signal for easy interface to common bus modules.
- On-board switches for manual control.
- Configurable for 2-wire control (Open input only) or 3wire control (Open/Close inputs).
- On-board +24VDC output to power feedback transmitter and/or open collector inputs.
- Built-in repeat cycle timer for *open*, *close*, or both.
- Control inputs are electrically isolated from one another.
- Control inputs are electrically isolated from the +24VDC and motor control outputs.

OUTLINE

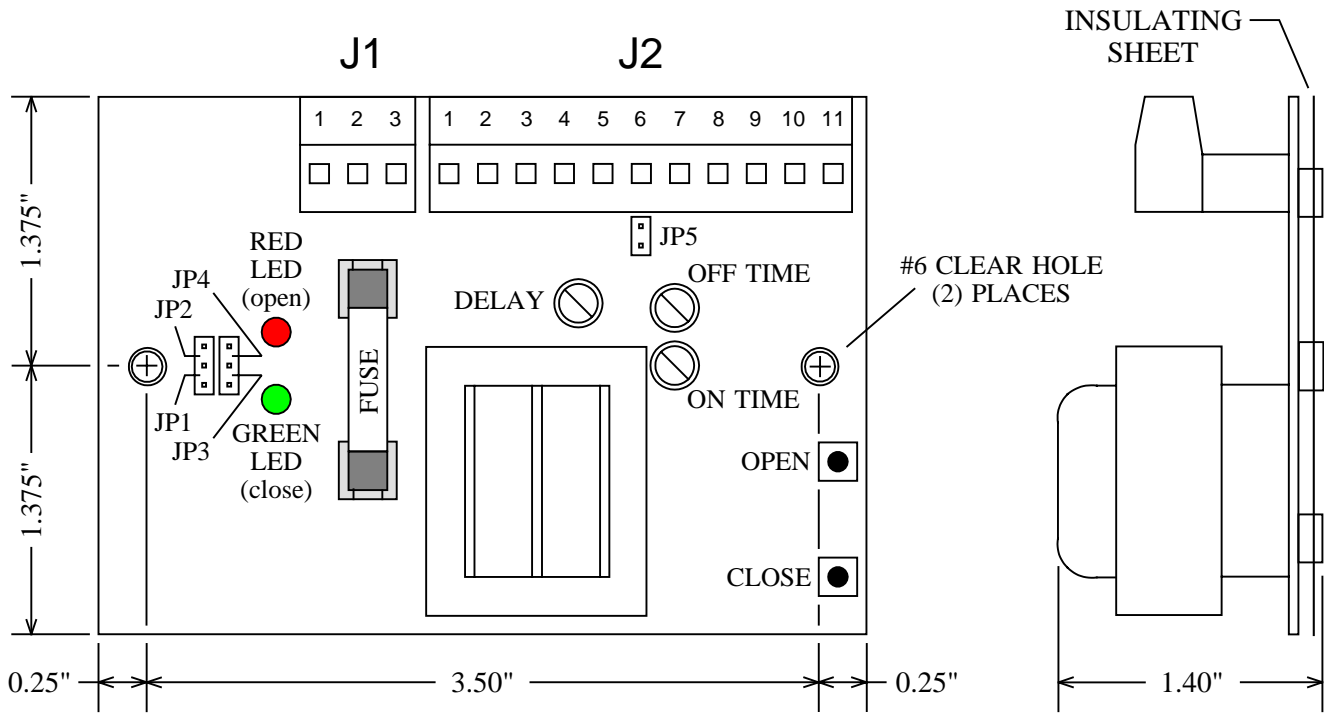

ELECTRICAL CONNECTIONS

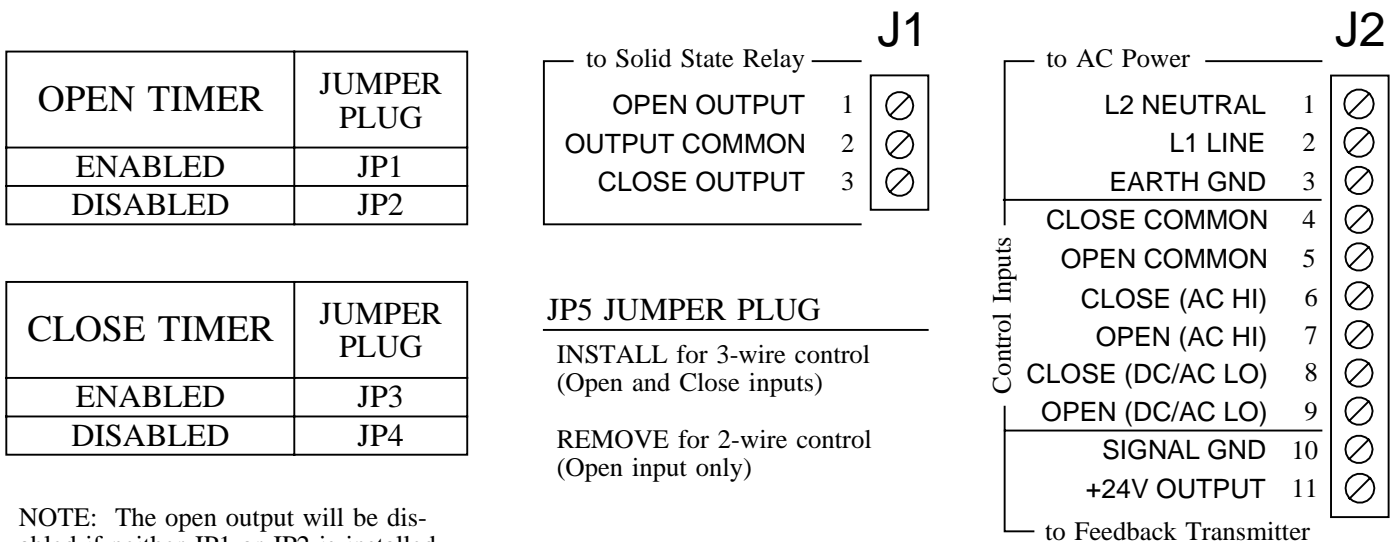

NOTE: The open output will be disabled if neither JP1 or JP2 is installed. Likewise, the close output is disabled if neither JP3 or JP4 is installed.

NOTE: Control Input connections are isolated from the Feedback Transmitter connections.

BLOCK DIAGRAM

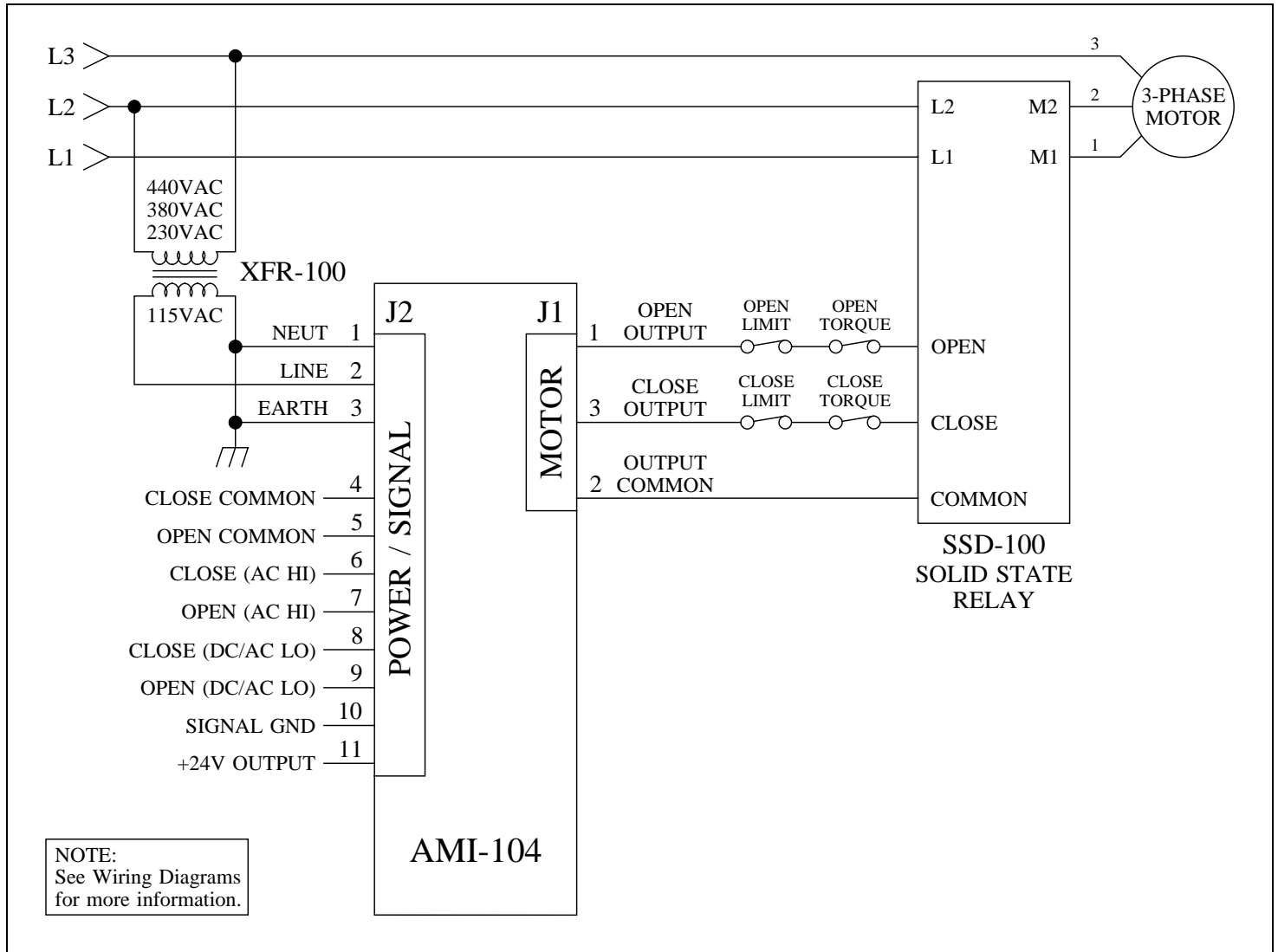

DESCRIPTION

The AMI-104 is specifically designed to drive a solid state relay, such as the Peaktronics SSD-100, which is used to switch power to the 3-phase motor windings. The unit is rated for 117VAC $\pm 10\%$ and is powered by a secondary AC source, usually a transformer, such as the Peaktronics XFR-100. To prevent damage to the solid state relay, the secondary AC source **must** be earth grounded as shown above. The unit comes with standoff mounts for direct mounting to a bracket (insulating sheet is included).

CAUTION ! These units are intended to be mounted in an appropriate enclosure to avoid electrical shocks. High voltages are present on the outside of the unit when power is applied. AC power should be disconnected prior to any wiring of these units. A heater and thermostat should be used where condensation may occur.

POWER / SIGNAL (J2)

Power is connected to pins 1, 2, and 3 as shown in the Block Diagram and is provided by a secondary AC source separate from the 3-phase motor power. The fuse installed on the unit is rated for safe operation of the unit. Replacement fuses should be of an equivalent size and type. Other fuse types can be used - consult the factory for appropriate substitutes.

The control signal to open the actuator is connected to either pin 7 or pin 9 (**do not** connect both inputs at the same time) using pin 5 (OPEN COMMON) as the return. The close control signal is connected to either pin 6 or pin 8 (**do not** connect both at the same time) using pin 4 (CLOSE COMMON) as the return. The AC HI inputs (pins 6 and 7) are suitable for 120VAC control signals, while the DC/AC LO inputs are used for either DC electronic signals (such as TTL, CMOS, etc.) or AC control signals up to 90VAC. Open collector control signals can also be used - see Wiring Diagrams for details.

Pin 11 of J2 provides an auxiliary +24VDC output which can be used to power an output transmitter. SIGNAL GND (pin 10) is used as the return line for the transmitter. OPEN COMMON (pin 5) and CLOSE COMMON (pin 4) are isolated from SIGNAL GND (pin 10). Pin 4 and 5 **should not** be connected to pin 10 when using control signals that are not isolated from the AC power line (pins 1, 2, and 3).

MOTOR (J1)

Pin 1 should be connected to the solid state relay input that moves the actuator toward the *open* position, and conversely, pin 3 is connected to the solid state relay input that moves the actuator toward the *closed* position. Pin 2 is internally connected to Signal Gnd (J2 pin 10) and is the common return for both outputs. When one of the outputs is turned on, it is internally connected to the +24VDC Output (J2 pin 11). The J1 connections are electrically isolated from the control signal inputs.

OUTPUT INDICATORS

The AMI-104 has on-board indicators that identify when one of the motor control outputs is turned on. When the open output is turned on, the red LED indicator will turn on, and when the close output is turned on the green LED indicator will turn on (see Outline).

Many actuators are equipped with limit switches at the *open* and *closed* positions which are intended to disconnect power to the motor to prevent mechanical damage. For this reason, it is possible that the AMI-104 will

indicate that one of the motor outputs is turned on when the actuator is not in motion. However, it should be noted that when the indicator is on, power is applied to the motor control output.

INPUT DELAY

Since 3-phase motors cannot be switched instantly between the Open and Close windings, the AMI-104 provides an input delay. If one output is on and the control signal inputs are switched to reverse the motor, the unit will delay turning on the other output. This delay is adjustable; see Specifications under "Control Adjustments" for delay period and Outline for location of the adjustment. When both outputs are off and a control input signal is applied, the Input Delay setting causes a delay in turning on the associated output. If the control signal is removed before the end of the delay period, the associated output will not turn on.

OPEN and CLOSE SWITCHES

The AMI-104 provides on-board switches that allow manual operation from the unit - see Outline for location of the switches. Pressing the *open* switch will turn on the Open output (J2 pin 1), while pressing the *close* switch turns on the Close output (J2 pin 3). Since the ON and OFF switches replace the control signal inputs, the Input Delay function effects the switch operation in the same manner as a control signal - refer to INPUT DELAY for more details.

To protect against turning on both outputs at the same time, the AMI-104 will not turn on one of the outputs until the other output has turned off. Additionally, if both control signals are applied at the same time, the unit will turn off both outputs. This is true of any combination of control signals or on-board switch operation. For example, if a PLC is applying a control signal to the CLOSE input while someone is pressing the *open* switch, both outputs will be turned off.

2-WIRE / 3-WIRE CONTROL (JP5)

JP5 is used to configure the unit for either 2-wire or 3-wire control - see Outline for location and setting of JP5. In 3-wire control, the Open input signal is used to turn on the Open output (J2 pin 1), and the Close input signal is used to turn on the Close output (J2 pin 3).

In 2-wire control, only the Open input signal is used, and the Close input terminals (J2 pins 4, 6, and 8) must not be connected. The Close output will always be turned on until the Open input signal is applied, at which time the Close output is turned off and the Open output will turn on. When the Open input signal is applied, the manual Open switch will have no effect, while the manual Close switch will turn off both outputs. When the Open input signal is not applied, the manual Close switch will have no effect, while the manual Open switch will turn off the Close output and turn on the Open output.

REPEAT CYCLE TIMER

The AMI-104 has a built-in repeat cycle timer that can be used to adjust the actuator speed. The timer automatically cycles the output on and off whenever the associated control input is applied. The ON time is adjustable from 0.1 to 2 seconds, while the OFF time is adjustable from 0.5 to 10 seconds. The timer function can be enabled or disabled for each output independently by installing jumpers for the desired operation. See Outline for location of adjustments and jumpers.

SPECIFICATIONS

POWER REQUIREMENTS

117VAC $\pm 10\%$, 50/60 Hz
 3.6 VA typical (not including output load)
 Fuse Type: 0.5A 3AG

AC HI CONTROL SIGNAL INPUTS

Maximum Input Voltage:
 130VAC 50/60 Hz (20 mA typical @ 60 Hz)
 Minimum ON Voltage:
 85VAC 50/60 Hz (13 mA typical @ 60 Hz)
 Maximum OFF Voltage:
 60VAC 50/60 Hz (8.8 mA typical @ 60 Hz)
 Maximum OFF State Input Current:
 7.5 mA @ 60 Hz / 6 mA @ 50 Hz

DC/AC LO CONTROL SIGNAL INPUTS

Maximum Input Voltage:
 130VDC (4 mA typical)
 90VAC 50/60 Hz (3.3 mA typical)
 Minimum ON Voltage:
 2.4VDC (0.4 mA maximum), TTL compatible
 1.9VAC (0.16 mA typical)
 Maximum OFF Voltage:
 1.8VDC
 1.3VAC
 Maximum OFF State Input Current:
 0.25 mA DC / 0.1 mA AC

+24V OUTPUT

24VDC $\pm 5\%$ @ 20mA max

DC CONTROL OUTPUTS

24VDC @ 25mA max

CONTROL ADJUSTMENTS

Cycle Timer, ON Time: 0.1 to 2 seconds
 Cycle Timer, OFF Time: 0.5 to 10 seconds
 Input Delay:
 0.056 to 1.5 second, switching inputs (3-wire)
 0.017 to 1 second, single input (3-wire)
 0.04 to 1.5 second (2-wire)

ENVIRONMENTAL

Operating Temperature Range: 0 °C to 60 °C
 Storage Temperature Range: -40 °C to 85 °C
 Relative Humidity Range: 0 to 90 % (noncondensing)

WIRING DIAGRAMS

Input Signal Configurations

(connect OPEN input only for 2-Wire Control)

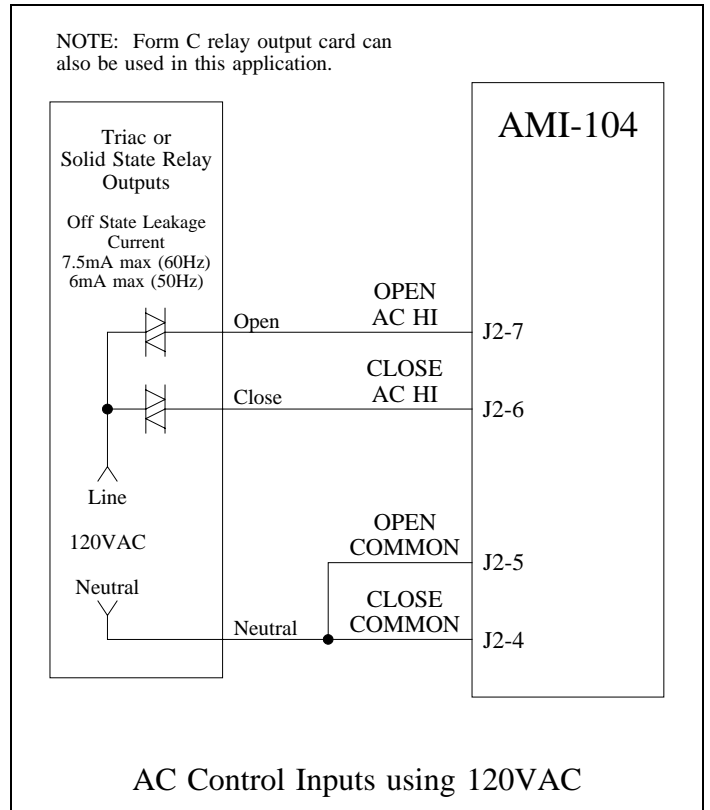
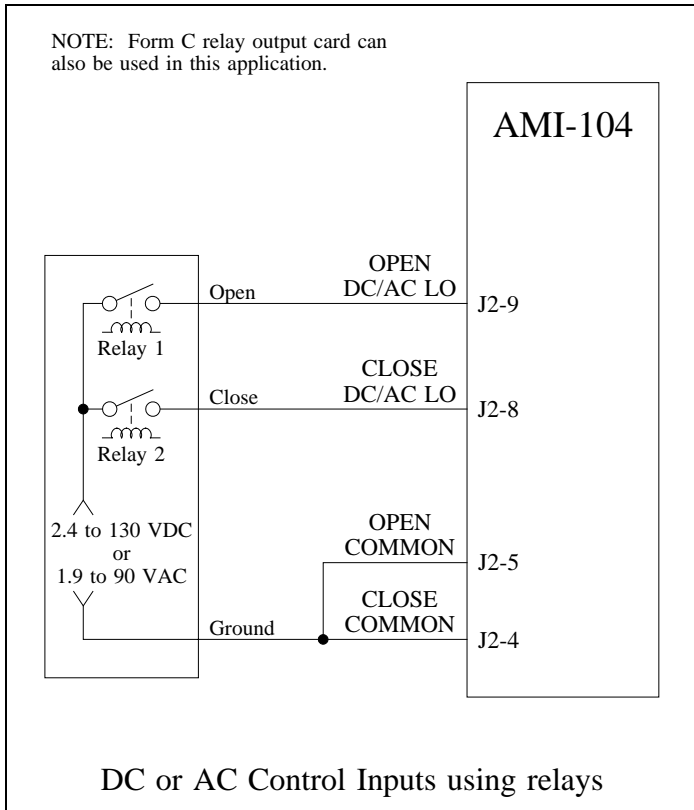
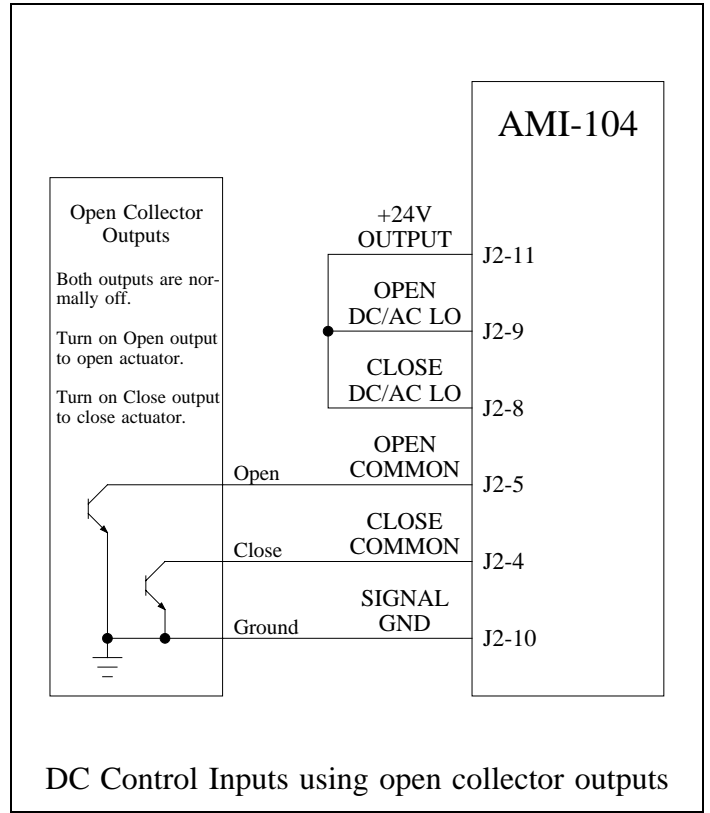
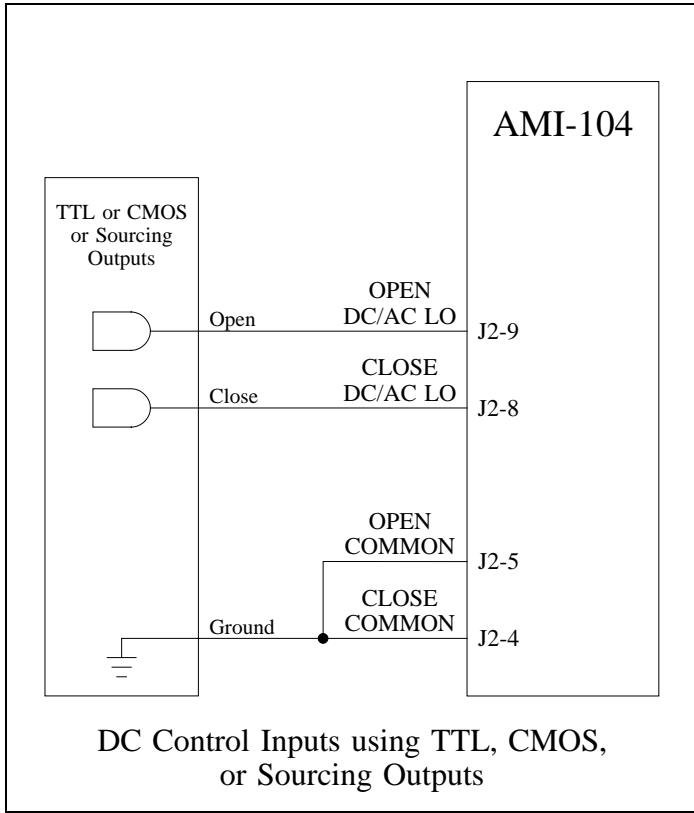

WIRING DIAGRAMS

Special Applications

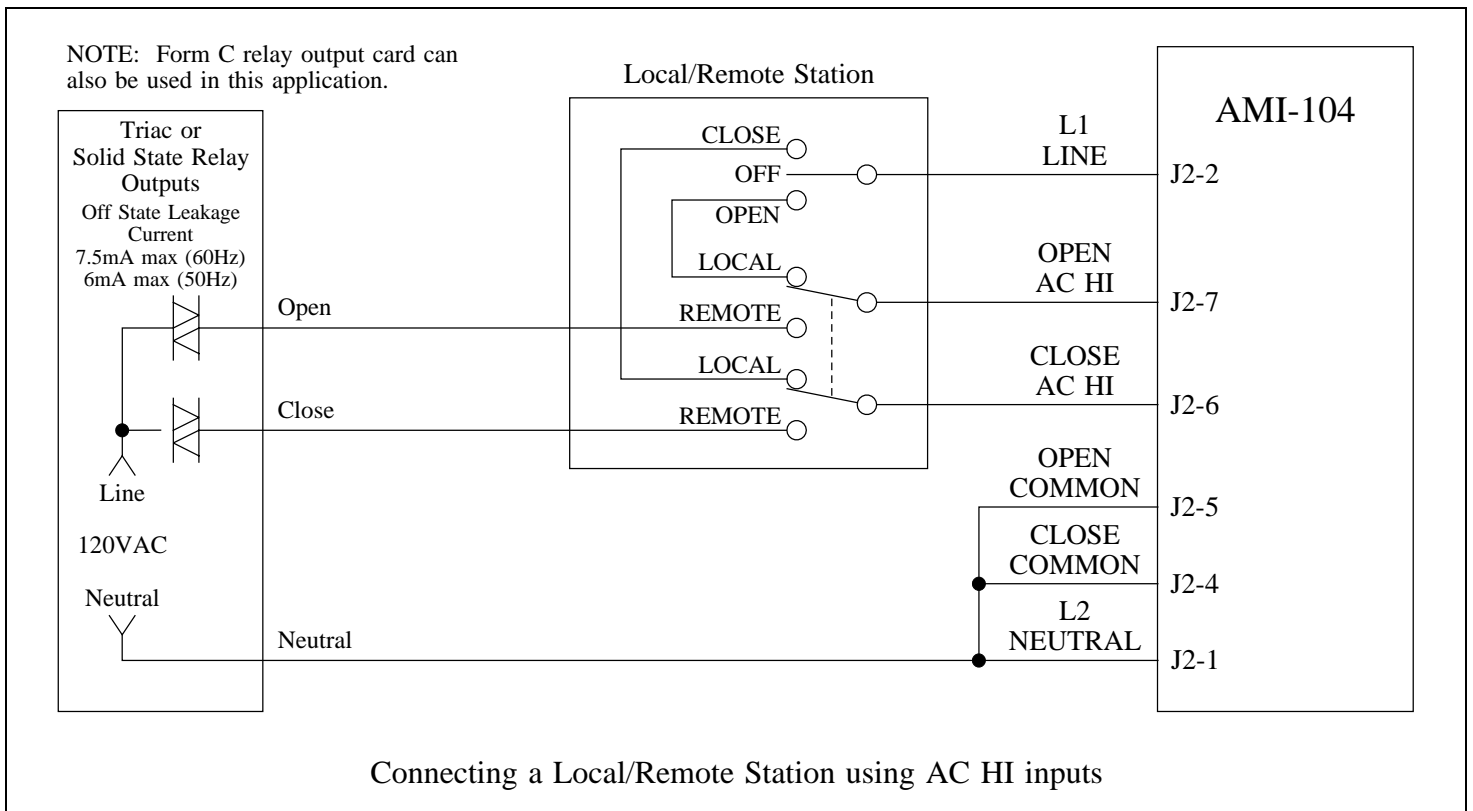
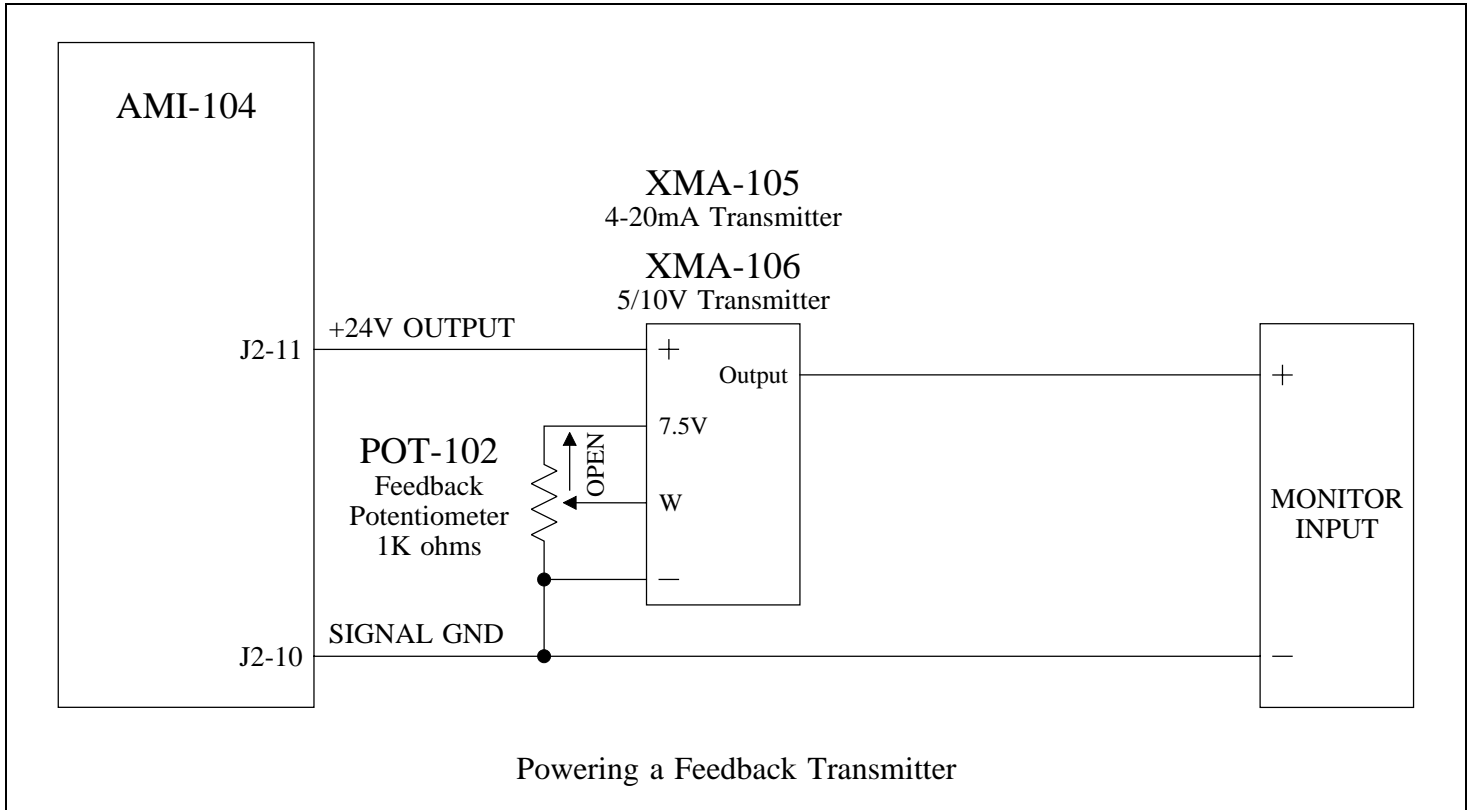

WIRING DIAGRAMS

Special Applications

