

ASSEMBLY DIAGRAM
for
Tyco EPI-3 Actuator

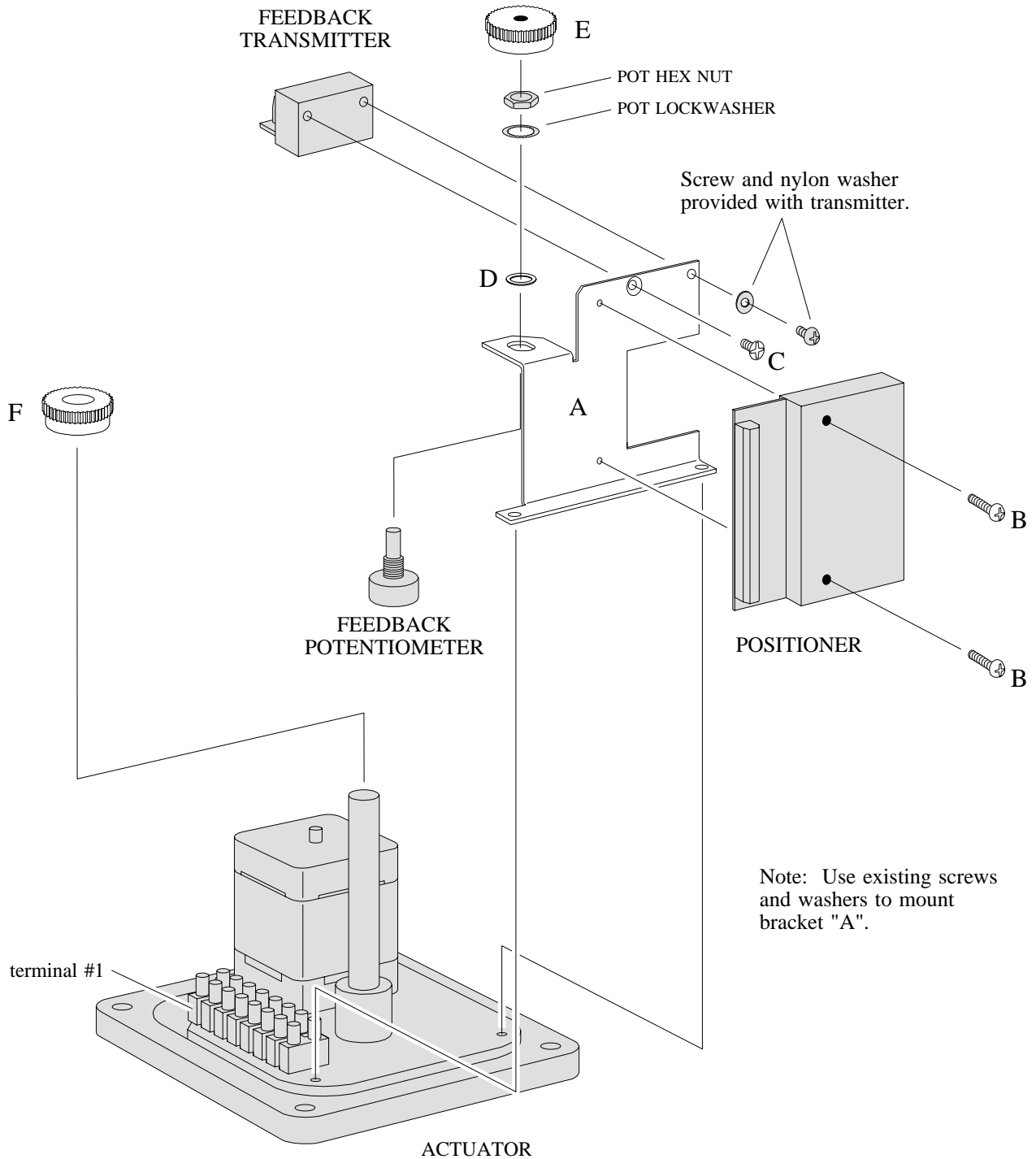

KIT CONTENTS

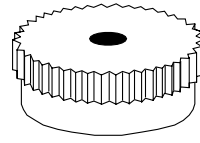
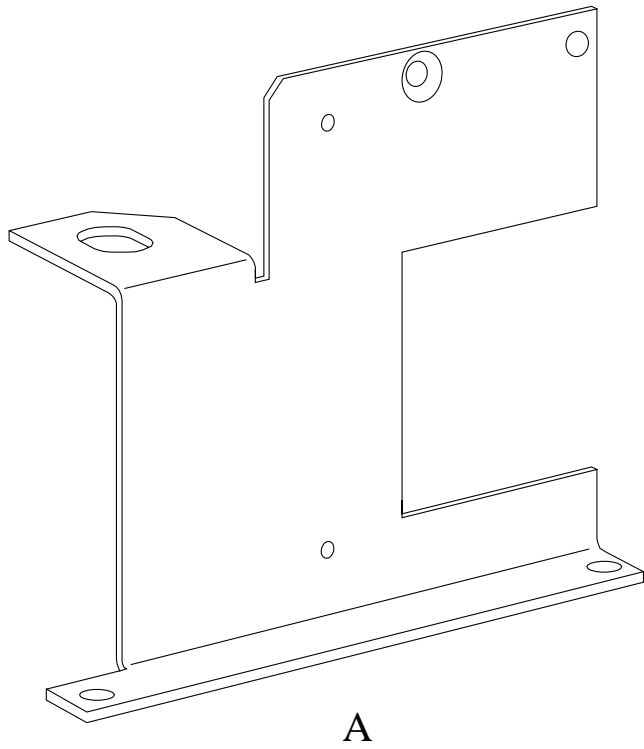

E

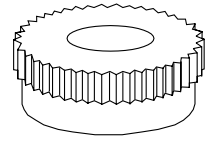

F

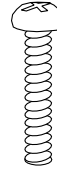

B



C



D

ITEM	QTY	DESCRIPTION
A	1	positioner bracket
B	2	#6-32 x 0.75" pan head screw
C	1	#6-32 x 0.375" undercut flat head screw
D	1	potentiometer anti-slip washer
E	1	potentiometer gear
F	1	output shaft gear
not shown	1	5" black wire
not shown	1	5" red wire
not shown	1	5" blue wire
not shown	1	4" purple wire (used on DC units only)
not shown	1	4" orange wire (used on DC units only)
not shown	2	6.3" nylon tie wrap

AC MOTOR CONTROLLERS

Wiring Diagram for Tyco EPI-3 continuous rated actuator

117VAC AMC-103
234VAC AMC-103A

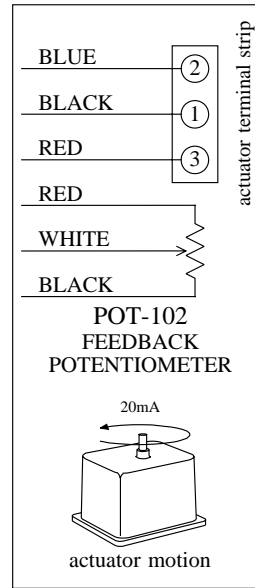
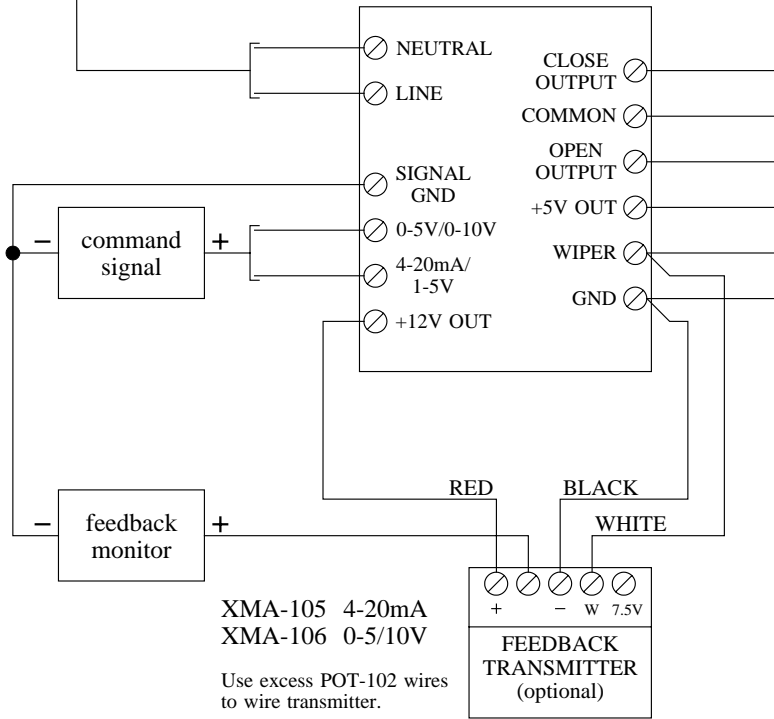

DIRECT ACTING

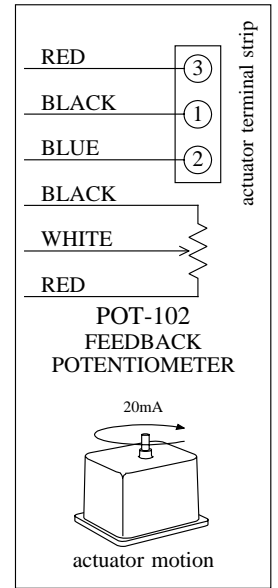

REVERSE ACTING

DC MOTOR CONTROLLER

Wiring Diagram for Tyco EPI-3 continuous rated actuator

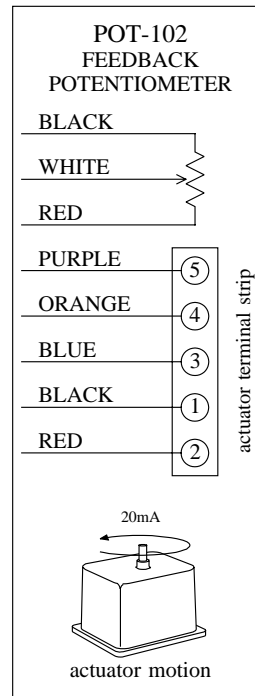
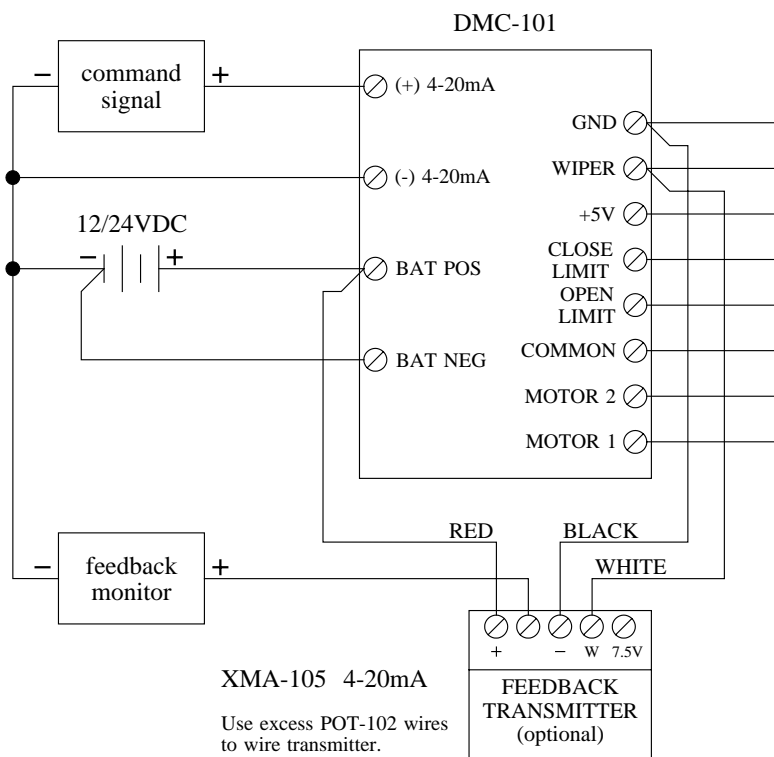

DIRECT ACTING

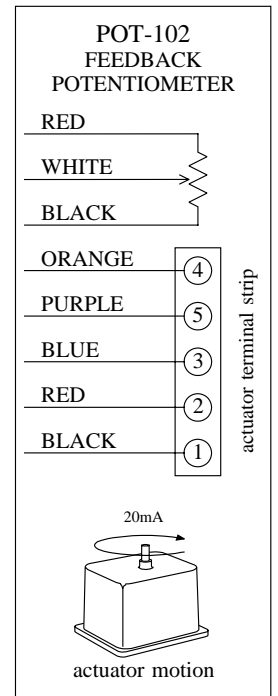

REVERSE ACTING

FEEDBACK TRANSMITTERS

Wiring Diagram for Tyco EPI-3 actuator

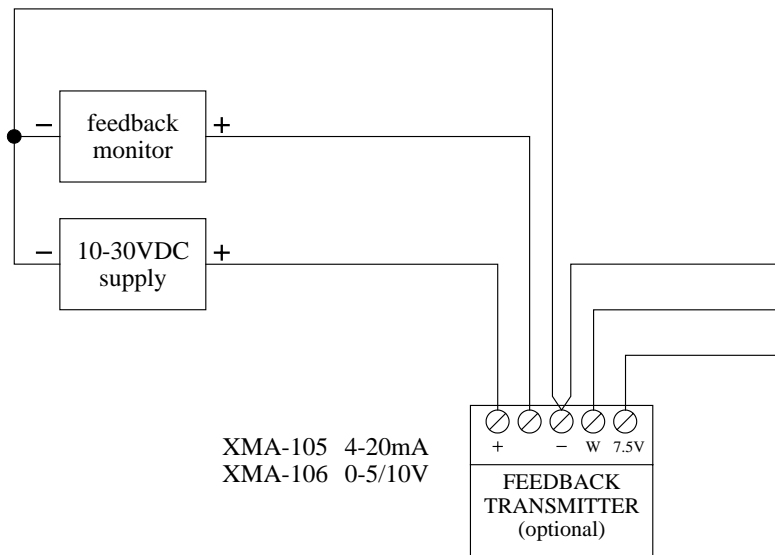

XMA-105 4-20mA
XMA-106 0-5/10V

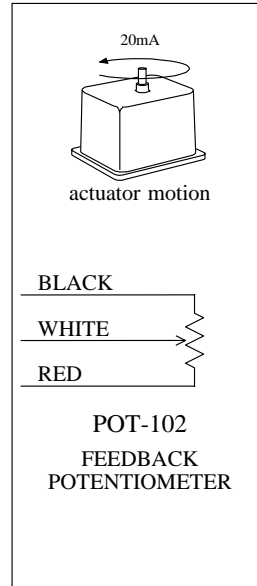

DIRECT ACTING

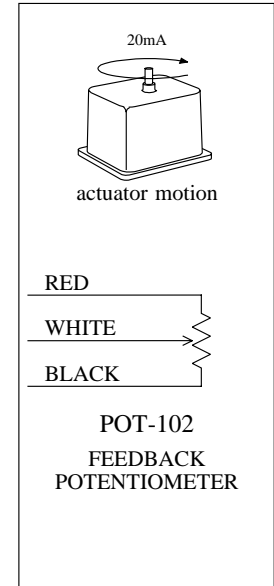

REVERSE ACTING