

ASSEMBLY DIAGRAM
for
Tyco EPI-Lite Actuator

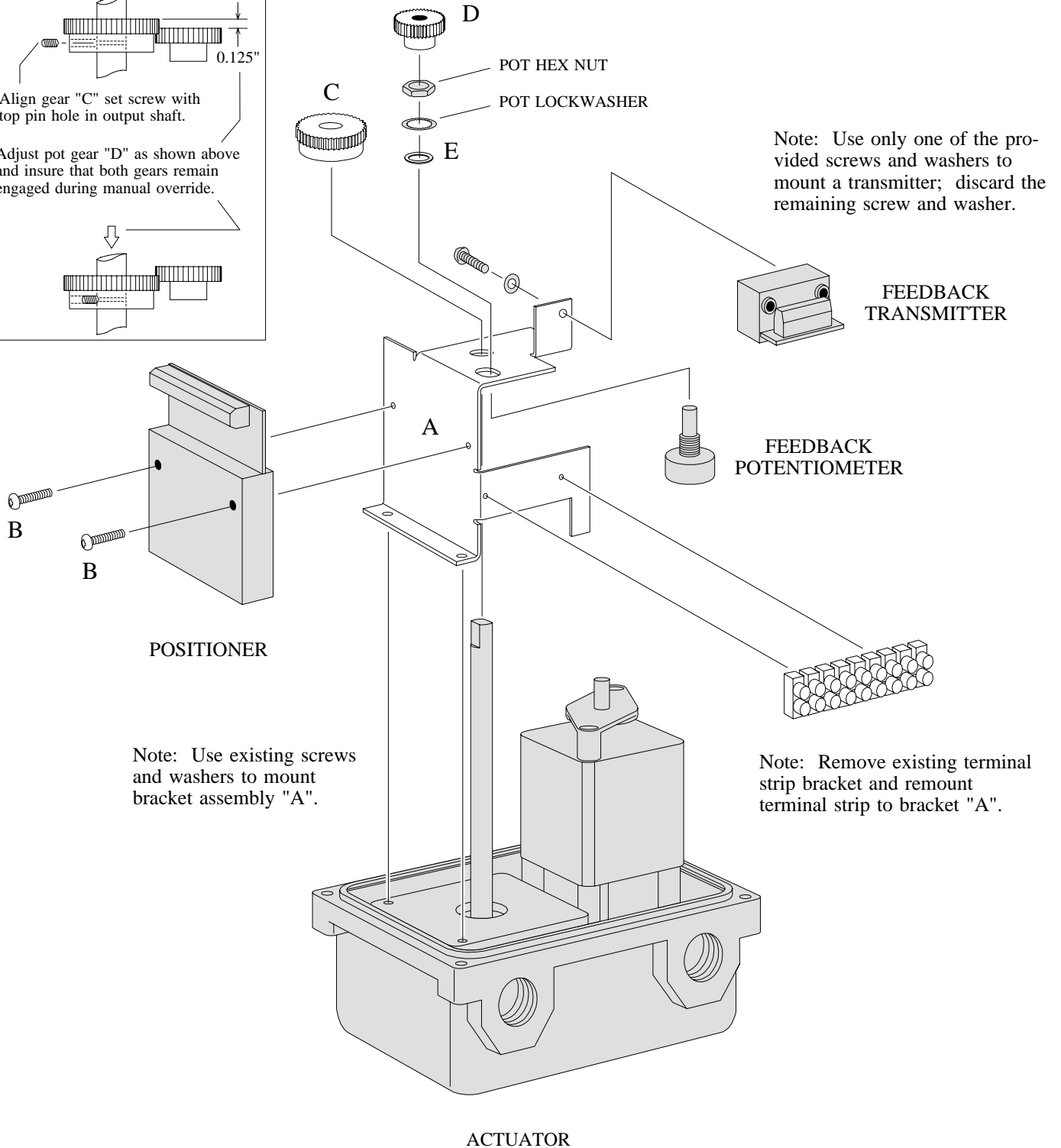

KIT CONTENTS

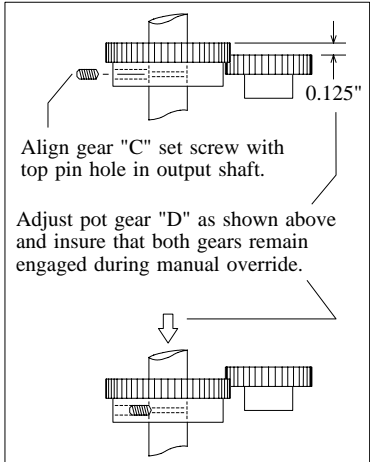
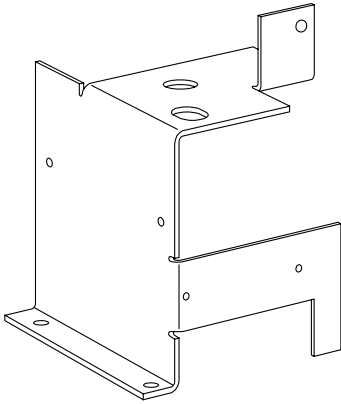

A

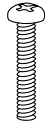

B

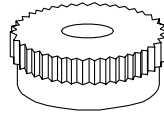

C

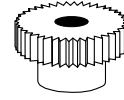

D



E

ITEM	QTY	DESCRIPTION
A	1	positioner bracket
B	2	#6-32 X 0.75" pan head screw
C	1	output shaft gear
D	1	potentiometer gear
E	1	potentiometer anti-slip washer
not shown	1	8" white wire
not shown	1	8" black wire
not shown	1	8" red wire
not shown	2	6.3" nylon tie wrap

AC POSITIONERS

Wiring Diagram for Tyco actuator
EPI Lite

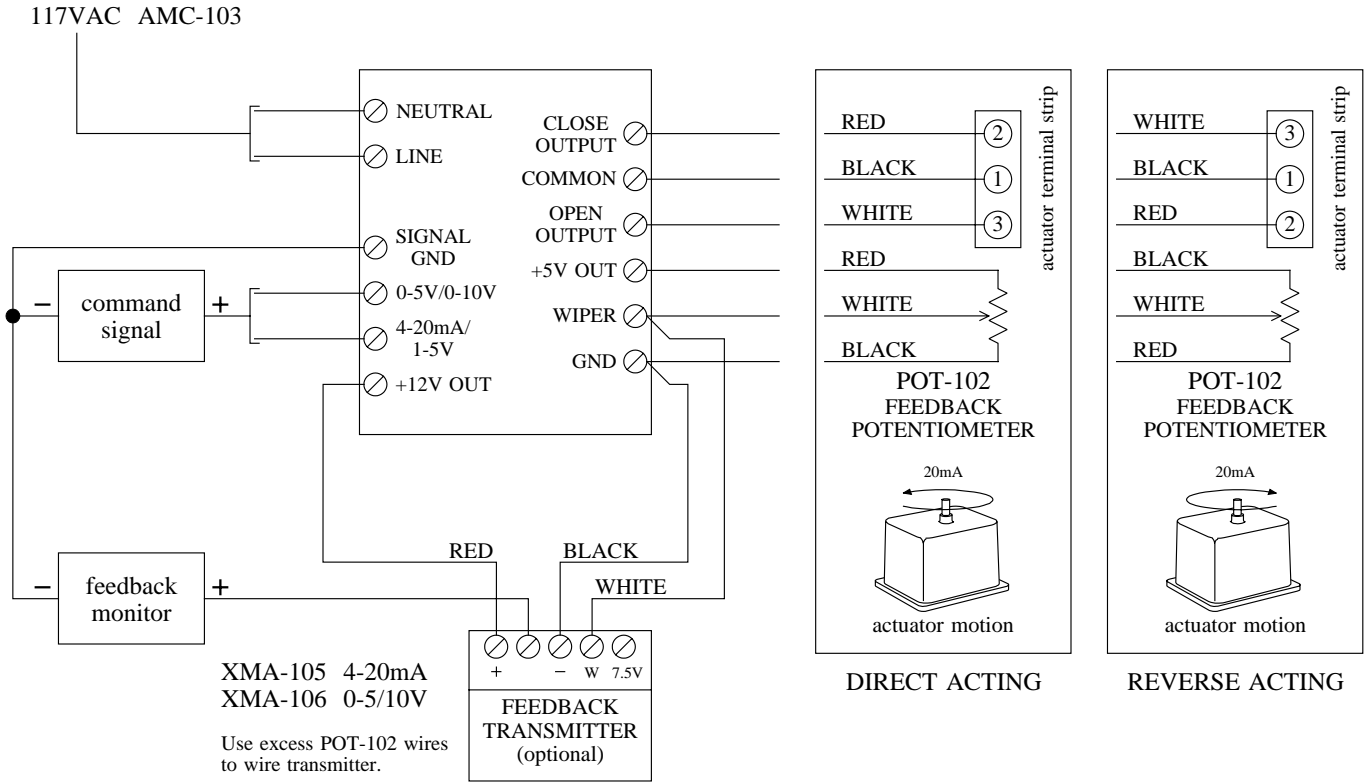

FEEDBACK TRANSMITTERS

Wiring Diagram for Tyco actuator
EPI Lite

