

Replacing Dual Feedback Pot with XMA-106 Voltage Transmitter

Many proportional positioning actuator applications still utilize a dual element feedback potentiometer (as shown in Figure 1) to provide a position feedback signal to a controller. When one of Peaktronics' positioners (AMC, LRC, or SVC series) is used in the application, the dual element pot is easily replaced with an XMA-106 Voltage Transmitter (shown in Figure 2).

A dual element pot is costly, and tends to be less accurate due to mechanical tracking between the elements. The controller using the feedback element must power the element, and further, needs to be calibrated for each actuator. Replacing the actuator or the controller will always require recalibration of the controller since the signal range is unknown.

The XMA-106 utilizes the feedback potentiometer used by the Peaktronics positioner which provides true position. Since the XMA-106 is powered by the positioner, only two wires are needed to provide feedback to the controller. The zero and span adjustments on the XMA-106 allow each actuator to be set to a known signal range (usually 0-5V or 0-10V), thus eliminating recalibration of the controller when replacing the actuator or the controller.

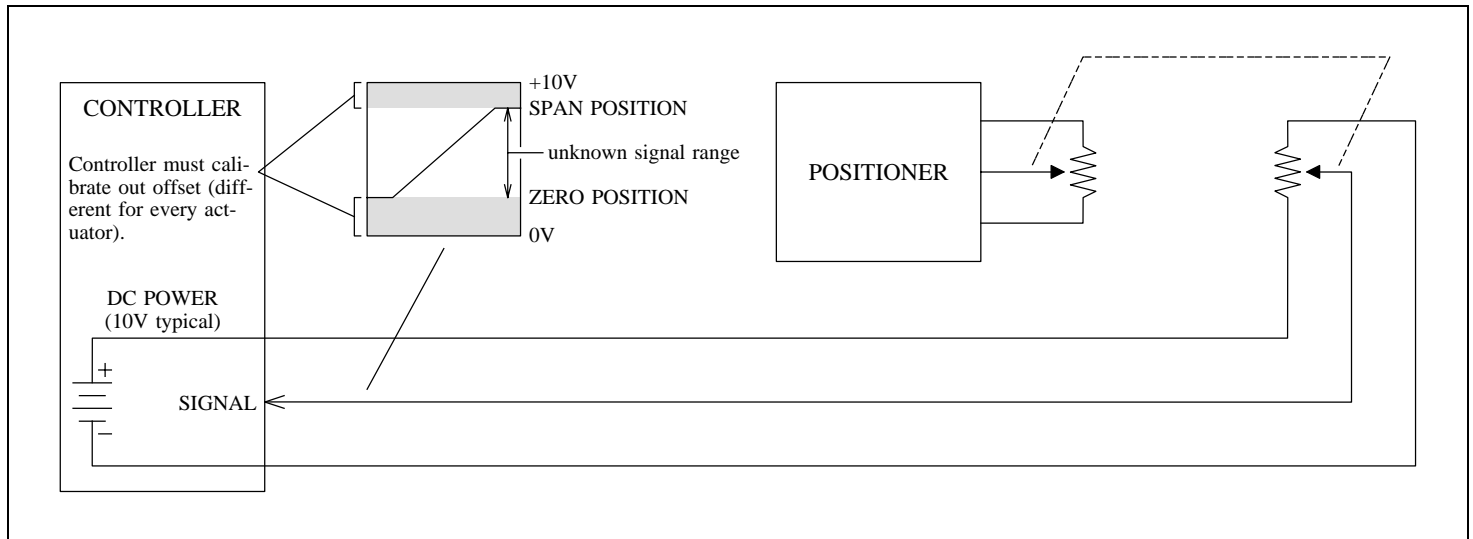

Figure 1 – Typical Dual Feedback Pot Application

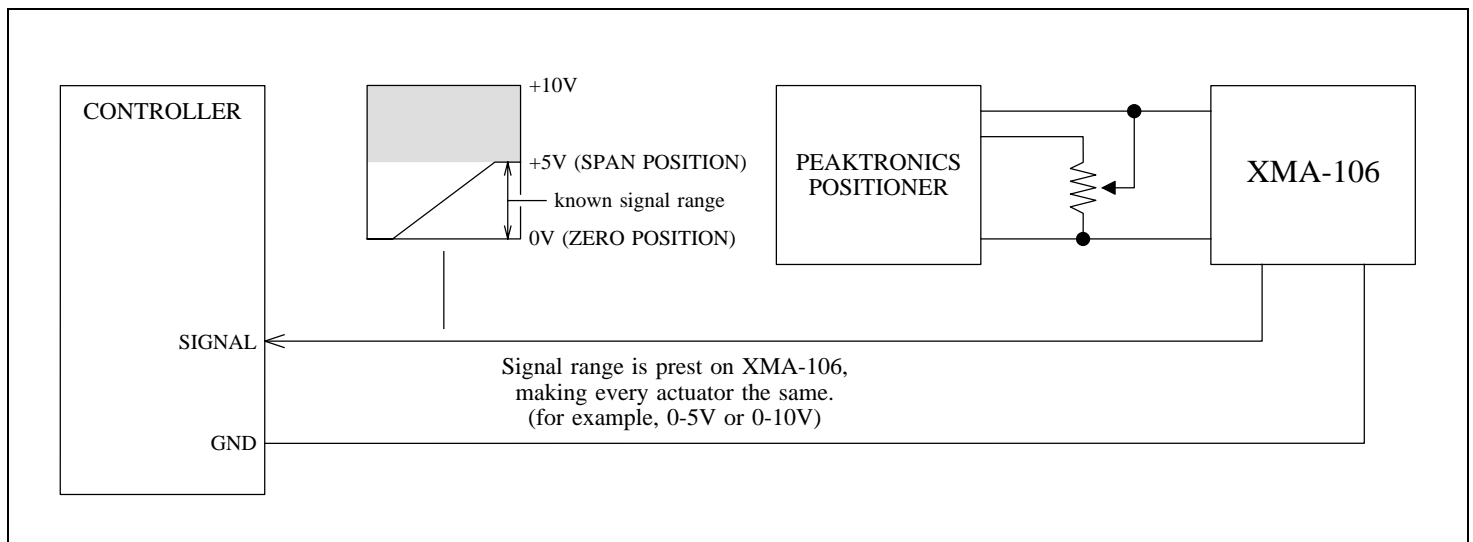

Figure 2 – Peaktronics XMA-106 Voltage Feedback Transmitter Application